

# **USER MANUAL**

**PA-J510**

**15" High Performance  
POS Terminal**

**PA-J510 M3**

---

---

# *PA-J510 15” High Performance POS Terminal*

## **COPYRIGHT NOTICE & TRADEMARK**

All trademarks and registered trademarks mentioned herein are the property of their respective owners.

This manual is copyrighted in June 2023. You may not reproduce or transmit in any form or by any means, electronic, or mechanical, including photocopying and recording.

## **DISCLAIMER**

This user’s manual is meant to assist users in installing and setting up the system. The information contained in this document is subject to change without any notice.

## **CE NOTICE**

This is a class A product. In a domestic environment this product may cause radio interference in which case the user may be required to take adequate measures.

---

---

---

---

## FCC NOTICE

This equipment has been tested and found to comply with the limits for a Class A digital device, pursuant to part 15 of the FCC Rules. These limits are designed to provide reasonable protection against harmful interference when the equipment is operated in a commercial environment. This equipment generates, uses, and can radiate radio frequency energy and, if not installed and used in accordance with the instruction manual, may cause harmful interference to radio communications. Operation of this equipment in a residential area is likely to cause harmful interference in which case the user will be required to correct the interference at his own expense.

You are cautioned that any change or modifications to the equipment not expressly approve by the party responsible for compliance could void your authority to operate such equipment.



**CAUTION:** Danger of explosion may occur when the battery is incorrectly replaced. Replace the battery only with the same or equivalent type recommended by the manufacturer. Dispose of used batteries according to the manufacturer's instructions.



**WARNING:** Some internal parts of the system may have high electrical voltage. We strongly recommend that only qualified engineers are allowed to service and disassemble the system. If any damages should occur on the system and are caused by unauthorized servicing, it will not be covered by the product warranty.

---

---

---

---

# Contents

<b>Revision History .....</b>	<b>v</b>
<b>1 Introduction .....</b>	<b>1-1</b>
1.1 About This Manual .....	1-2
<b>2 Getting Started .....</b>	<b>2-1</b>
2.1 Package List.....	2-2
2.2 System Overview .....	2-3
2.2.1 Panel PC.....	2-3
2.2.2 Normal Stand Only.....	2-4
2.2.3 Normal Stand with 10.1" 2nd Display .....	2-5
2.3 System Specifications .....	2-6
2.4 Safety Precautions .....	2-8
<b>3 System Configuration.....</b>	<b>3-1</b>
3.1 System External I/O Ports Diagram .....	3-2
3.2 Mainboard Component Locations & Jumper Setting .....	3-3
3.3 How to Set Jumpers.....	3-4
3.4 Main Board Connector & Jumper Quick Reference Table .....	3-6
3.5 Setting Main Board Connectors and Jumpers .....	3-7
3.5.1 Power Switch .....	3-7
3.5.2 DC IN Connector (DC In).....	3-7
3.5.3 1st Display Port (MDP1) .....	3-8
3.5.4 COM Ports (COM1, COM2).....	3-9
3.5.5 LAN Port (LAN1).....	3-10
3.5.6 USB Type C Port (USB Type C) .....	3-11
3.5.7 Dual USB 2.0 Ports (USB2).....	3-12

---

3.5.8	Dual USB 3.0 Ports (USB1).....	3-12
3.5.9	2nd Display Port (MDP2).....	3-13
3.5.10	HDMI Port Connector (HDMI1).....	3-14
3.5.11	Cash Drawer Port (DRW) .....	3-15
3.5.12	Internal USB Wafer (JUSB1, JUSB9).....	3-18
3.5.13	Internal USB Wafer (JUSB7) .....	3-19
3.5.14	M.2 M-Key Connector for SSD (M2_M1).....	3-20
3.5.15	M.2 M-Key Connector for SSD (M2_M2).....	3-22
3.5.16	M.2 E-Key Connector for Wi-Fi (M2_E1).....	3-24
3.5.17	Speaker Wafer (JSPK1).....	3-26
3.5.18	Microphone Connector (JMIC1).....	3-26
3.5.19	Power Output 24V Wafer (J24V_OUT1).....	3-26
3.5.20	System LED Wafer (JSYS_LED1).....	3-27
3.5.21	CPU Fan Wafer (CPU_FAN1).....	3-27
3.5.22	Power Button Wafer (JPWRBTN1).....	3-28
3.5.23	Battery Wafer (JBAT1) .....	3-28
3.5.24	System Reset Wafer (JRST1).....	3-28
3.5.25	USB Signal Selection (JP1).....	3-29
3.5.26	USB Signal Selection (JP2).....	3-29
3.5.27	Cash Drawer Voltage Selection (JP3) .....	3-30
3.5.28	Clear CMOS Data Selection (JPCMOS1) .....	3-31
3.6	A/D Board Component Locations & Jumper Setting.....	3-32
3.7	A/D Board Connector & Jumper Quick Reference Table .....	3-33
3.8	Setting A/D Board Connectors and Jumpers .....	3-34
3.8.1	1st Display Port Connector (MDP1).....	3-34
3.8.2	Embedded DisplayPort Connector (JEDP2).....	3-35
3.8.3	Speaker Connector (JSPK1) .....	3-36
3.8.4	Inverter Connector (JINV1).....	3-36
3.8.5	LVDS Connector (LVDS1).....	3-37

---

3.8.6	USB 2.0 Connector (JUSB1, JUSB2, JUSB3).....	3-38
3.8.7	Backlight Voltage Selection (JP_INV1).....	3-39
3.8.8	LVDS Panel Voltage Control Selection (JP_VDD1).....	3-39
3.8.9	LVDS Backlight Control (JP1).....	3-40
<b>4</b>	<b>Software Utilities .....</b>	<b>4-1</b>
4.1	Introduction.....	4-2
4.1.1	Installing Intel® Chipset Software Installation Utility .....	4-3
4.1.2	Installing Graphics Driver Utility.....	4-4
4.1.3	Intel® Management Engine Components Installer Installation. .....	4-5
4.1.4	Installing LAN Driver Utility .....	4-6
4.1.5	Installing Intel® Serial I/O Driver Utility.....	4-7
4.1.6	Installing Sound Driver Utility.....	4-8
<b>5</b>	<b>BIOS SETUP .....</b>	<b>5-1</b>
5.1	Introduction.....	5-2
5.1.1.1	Accessing Setup Utility .....	5-4
5.1.2	Main .....	5-7
5.1.3	Advanced .....	5-8
5.1.3.1	Advanced - CPU Configuration.....	5-10
5.1.3.2	Advanced - PCH-FW Configuration.....	5-11
5.1.3.3	Advanced - Trusted Computing .....	5-13
5.1.3.4	Advanced - ACPI Settings .....	5-15
5.1.3.5	Advanced - F81967 Super IO Configuration .....	5-16
5.1.3.6	Advanced - Hardware Monitor .....	5-19
5.1.3.7	Advanced - F81967 Watchdog .....	5-22
5.1.3.8	Advanced - USB Configuration.....	5-23
5.1.3.9	Advanced - NVMe Configuration .....	5-24
5.1.4	Chipset.....	5-25
5.1.4.1	System Agent (SA) Configuration .....	5-26

---

5.1.4.2	PCH IO Configuration .....	5-28
5.1.5	Security .....	5-31
5.1.6	Boot.....	5-33
5.1.7	Save & Exit .....	5-35
<b>Appendix A System Diagrams .....</b>		<b>A-1</b>
	PPC Memory Maintenance.....	A-2
	PPC M.2 2280 Maintenance.....	A-4
	PA-J510 Memory Maintenance .....	A-5
	PA-J510 M.2 2280 Maintenance .....	A-7
	How To Turn System Touchscreen .....	A-8
	2nd Display Assembly .....	A-9
	VFD Module Assembly .....	A-12
	iButton Module Assembly .....	A-14
	Fingerprint Module Assembly .....	A-15
	Barcode Scanner Assembly .....	A-16
	MSR Module Assembly .....	A-17
	POS Type Assembly Exploded Diagram .....	A-18
	PPC Type Assembly Exploded Diagram .....	A-19
<b>Appendix B Technical Summary .....</b>		<b>B-1</b>
	Block Diagram .....	B-2
	Interrupt Map .....	B-3
	I/O MAP .....	B-18
	Memory Map.....	B-20
	Configuring WatchDog Timer .....	B-23
	Flash BIOS Update.....	B-25

---

---

## Revision History

The revision history of PA-J510 User Manual is described below:

Version No.	Revision History	Date
M3	Added: The default voltage of Cash Drawer is "default at <b>+24V</b> ". (Page 2-6)	2023/6/15
M2	The description of Section 3.5.11 Cash Drawer Port (DRW) has been revised. (Page 3-15)	2023/4/25
M1	Initial Release	2023/4/10



# 1

## Introduction

---

---

This chapter provides the introduction for PA-J510 system as well as the framework of the user manual.

The following topic is included:

- About This Manual

## **1.1 About This Manual**

Thank you for purchasing our PA-J510 system. The PA-J510 is an updated system designed to be comparable with the highest performance of IBM AT personal computers. The PA-J510 provides faster processing speed, greater expandability and can handle more tasks than before. This manual is designed to assist you how to install and set up the whole system. It contains 5 chapters and 2 appendixes. Users can configure the system according to their own needs. This user manual is intended for service personnel with strong hardware background. It is not intended for general users.

The following section describes the structure of this user manual.

### ***Chapter 1 Introduction***

This chapter introduces the framework of this user manual.

### ***Chapter 2 Getting Started***

This chapter describes the package contents and system specifications, and illustrates the physical appearances for PA-J510 system. Read the safety reminders carefully on how to take care of your system properly.

### ***Chapter 3 System Configuration***

This chapter describes the locations and functions of the system main board components. You will learn how to properly configure the connectors and system configuration jumpers on the main board and configure the system to meet your own needs.

### ***Chapter 4 Software Utilities***

This chapter introduces how to install Intel Chipset Software Installation Utility, Graphics Driver Utility, Intel Management Engine Components Installer Driver Utility, LAN Driver Utility, Serial IO Driver Utility and Sound Driver Utility.

### ***Chapter 5 BIOS Setup***

This chapter provides BIOS setup information.

### ***Appendix A System Diagrams***

This appendix provides the exploded diagrams and part numbers of PA-J510.

### ***Appendix B Technical Summary***

This appendix provides the information about the system block diagram, allocation maps for system resources, Watchdog Timer Configuration and Flash BIOS Update.

# 2

## Getting Started

---

---

This chapter provides the introduction for the PA-J510 system as well as the framework of the user manual.

The following topic is included:

- About This Manual
- POS System Illustration
- System Specifications
- Safety precautions

**Experienced users can jump to Chapter 3 on page 3-1 for a quick start.**

## **2.1 Package List**

If you discover any of the items listed below are damaged or lost, please contact your local distributor immediately.

<b>Item</b>	<b>Q'ty</b>
PA-J510 POS System	1
Manual / Driver DVD	1
Power Adapter	1
Power Cord	1

## 2.2 System Overview

Unit: mm

### 2.2.1 Panel PC

Front View

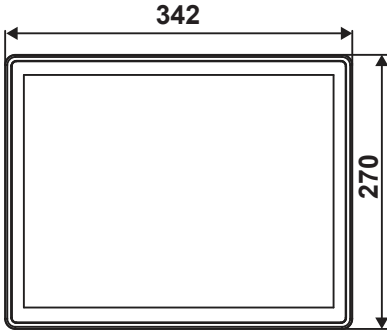

Rear View

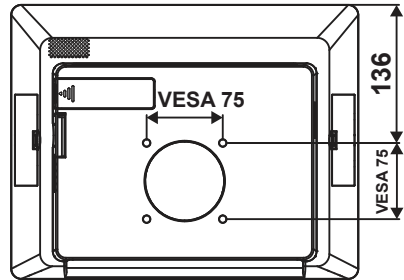

Side View

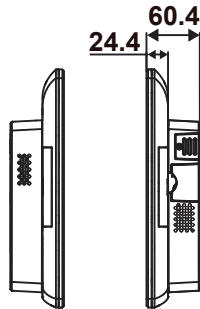

2.2.2 Normal Stand Only

Unit: mm

Front View

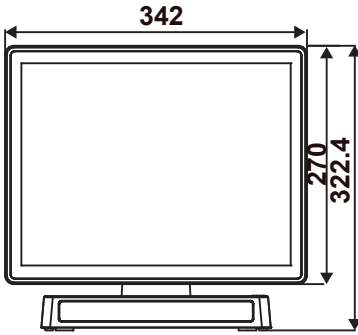

Rear View

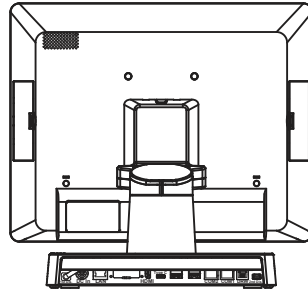

Side View

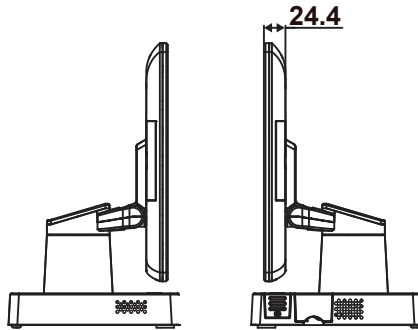

2.2.3 Normal Stand with 10.1" 2nd Display

Unit: mm

Front View

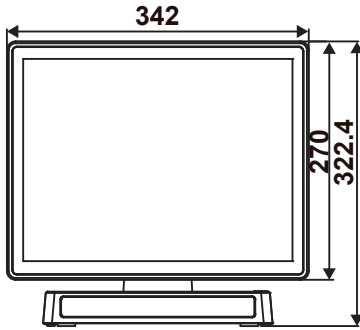

Rear View

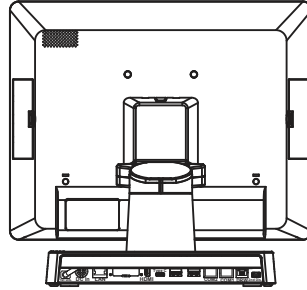

Side View

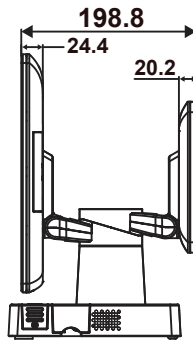

## 2.3 System Specifications

System	
CPU Support	➤ Intel® Core® i5-1145G7E / i3-1115G4E / Celeron® 6305E / Pentium® 7505 CPU
Memory	➤ 1 x DDR4 SO-DIMM slot (up to 16GB)
Network	➤ 1 x Gigabit 10/100/1000 Base-T Fast Ethernet ➤ 1 x M.2 (E Key, 2230)
Power Supply	➤ 1 x 60/90 watt power adapter
Audio	➤ 1 x 2W speaker
System Weight	➤ <b>PPC:</b> 3.9 kg ➤ <b>POS:</b> 4.3 kg ➤ <b>POS + 2nd Display:</b> approx. 5.3 kg (w/o power adapter)
Dimensions (W x H x D)	➤ <b>PPC:</b> 342 x 270 x 60mm ➤ <b>POS:</b> 342 x 270 x 195 mm (45 degree) ➤ <b>POS + 2nd Display:</b> 342 x 291 x 237 mm (45 degree)
O.S. Support	➤ Windows® 11 / Windows® 10 IoT Enterprise
Wall Mount Type	➤ VESA 75 x 75mm standard
Storage	
SATA	➤ 1 x M.2 2280, SATA interface
I/O Ports	
Display	➤ 1 x Mini DP for Primary display (for Protech original display only) ➤ 1 x Mini DP for 2nd display (for Protech original display only) ➤ 1 x HDMI 1.4
USB	➤ <b>Rear I/O:</b> 2 x USB 2.0/ 2 x USB 3.1/ 1 x USB Type-C ➤ <b>Side I/O:</b> 1 x USB 2.0
Serial Port	➤ 1 x RJ45 (support +5V/12V selectable)
LAN	➤ 1 x Giga LAN
Cash Drawer	➤ 1 x RJ11 (+12V or +24V selectable) (Default at +24V)
DC In	➤ 1 x 4-pin DC power jack
Option	➤ 1 x USB 2.0 or 1 x 24V Power USB (1A) or 1 x DC Out (1A)



<b>Add-Ons</b>	
Customer Display	➤ 20 columns x2 lines STN LCD display
MSR & i-Button	➤ ISO I,II,III;JIS II and support information key (USB interface)
Fingerprint	➤ Silicon Fingerprint Module (USB interface)
Barcode Scanner	➤ <b>1D:</b> EAN-13, EAN-8, UPC-A, UPC-E, ISSN, ISBN, Codabar, Code 128, Code 93, ITF-6, ITF-14, Interleaved 2 of 5, Industrial 2 of 5, Standard 2 of 5, Matrix 2 of 5, GS1 Databar, Code 39, Code 11 ➤ <b>2D:</b> PDF417, QR Code, Micro QR, Data Matrix, Chinese sensible code
<b>Display</b>	
LCD	➤ 15" IPS LCD (Resolution: 1024 x 768) ➤ Brightness: 400 cd/m <sup>2</sup>
Touchscreen	➤ Bezel-free projected capacitive
Tilt Angle	➤ 0~50 degree
<b>Environment</b>	
EMC & Safety	➤ CE / FCC
Operating Temp.	➤ 0°C ~ 35°C (32°F ~ 95°F)
Storage Temp.	➤ -20°C ~ 60°C (-4°F ~ 140°F)
Humidity	➤ 20% ~ 90%

## **2.4 Safety Precautions**

Before operating this system, read the following information carefully to protect your systems from damages, and extend the life cycle of the system.

1. Check the Line Voltage
  - The operating voltage for the power supply should be within the range of 100V to 240V AC; otherwise, the system may be damaged.
  
2. Environmental Conditions
  - Place your PA-J510 on a sturdy, level surface. Be sure to allow enough space around the system to have easy access needs.
  - Avoid installing your PA-J510 system in extremely hot or cold places.
  - Avoid direct sunlight exposure for a long period of time (for example, in a closed car in summer time. Also avoid the system from any heating device.). Or do not use PA-J510 when it has been left outdoors in a cold winter day.
  - Bear in mind that the operating ambient temperature is between 0°C and 35°C (32°F and 95°F).
  - Avoid moving the system rapidly from a hot place to a cold place, and vice versa, because condensation may occur inside the system.
  - Protect your PA-J510 from strong vibrations which may cause hard disk failure.
  - Do not place the system too close to any radio-active device. Radio-active device may cause signal interference.
  - Always shut down the operating system before turning off the power.
  
3. Handling
  - Avoid placing heavy objects on the top of the system.
  - Do not turn the system upside down. This may cause the hard drive to malfunction.
  - Do not allow any objects to fall into this device.
  - If water or other liquid spills into the device, unplug the power cord immediately.

# 3

## System Configuration

---

---

This chapter provides the information for the PA-J510 system. It describes the jumper and connector settings, component locations, and pin assignment.

The following topics are included:

- System External I/O Port Diagram
- Mainboard Component Locations & Jumper Setting
- How to Set Jumpers
- Setting Connectors and Jumpers

### 3.1 System External I/O Ports Diagram

#### Rear I/O

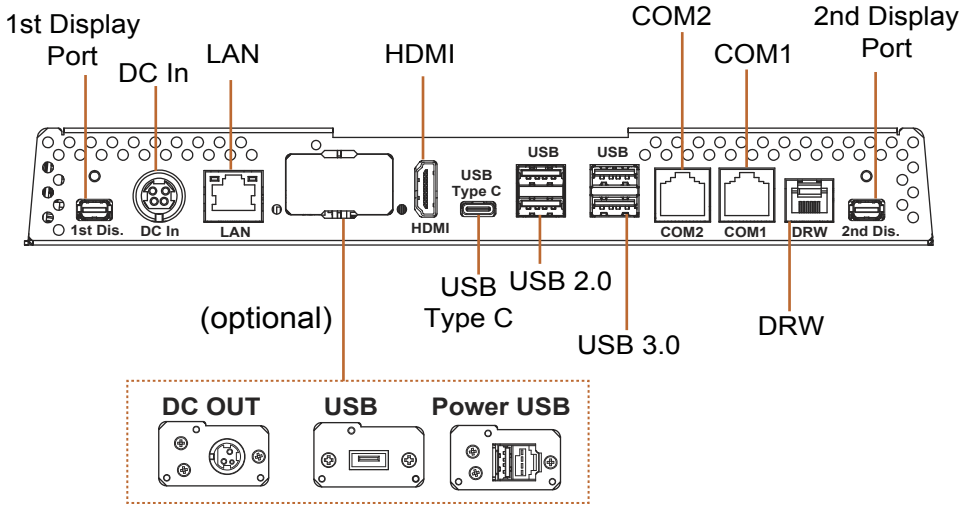

#### Side I/O

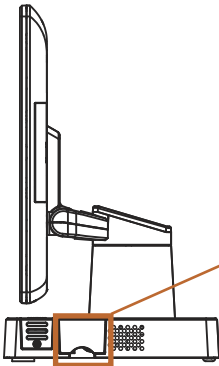

Open up the cover from the right side of PA-J510 Box as shown and find the Side I/O **USB7** and Power Button.

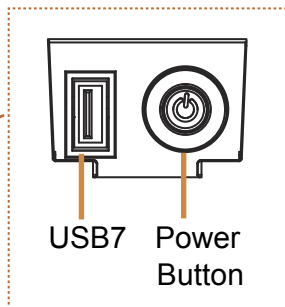

### 3.2 Mainboard Component Locations & Jumper Setting

M/B: PB-J500

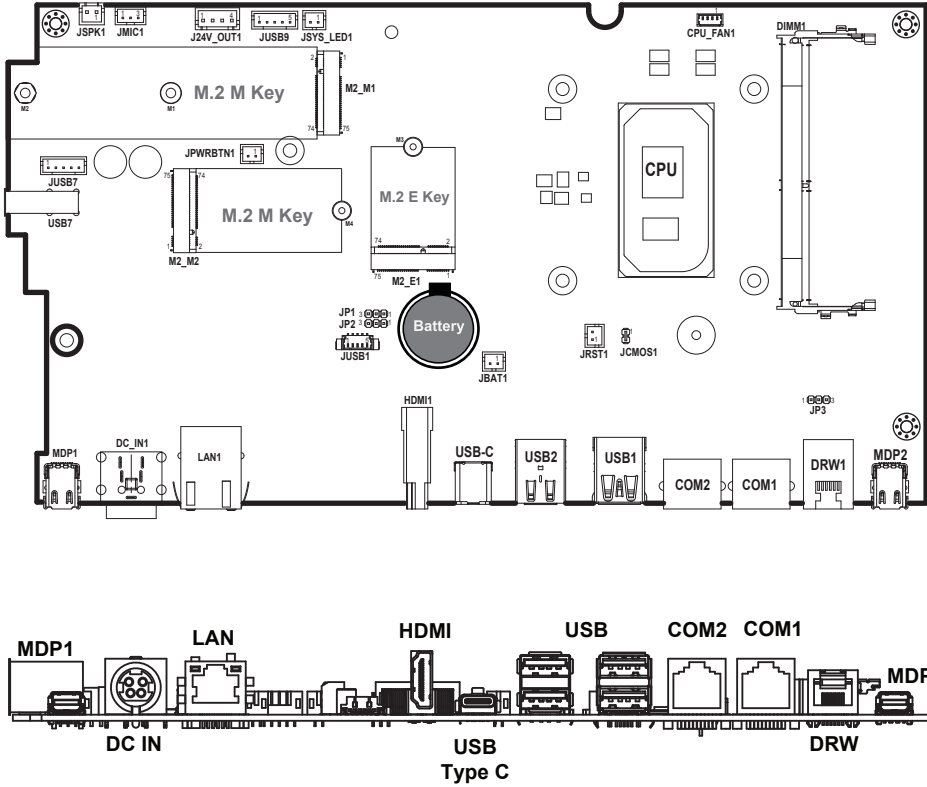

### 3.3 How to Set Jumpers

You can configure your board by setting the jumpers. A jumper consists of two or three metal pins with a plastic base mounted on the card, and by using a small plastic "cap", also known as the jumper cap (with a metal contact inside), you are able to connect the pins. So you can set-up your hardware configuration by "opening" or "closing" pins.

Jumpers can be combined into sets that called jumper blocks. When jumpers are all in the block, you have to put them together to set up the hardware configuration. The figure below shows what this looks like.

#### Jumpers & Caps

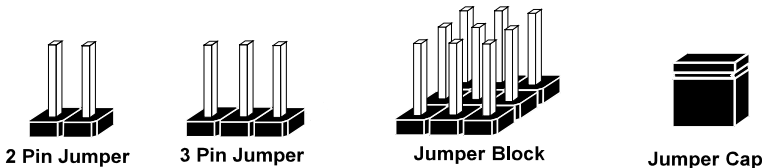

If a jumper has three pins, for example, labeled PIN1, PIN2 and PIN3. You can connect PIN1 and PIN2 to create one setting and shorting. You can also select to connect PIN2 and PIN3 to create another setting. The same jumper diagrams are applied all through this manual. The figure below shows what the manual diagrams look and what they represent.

### Jumper diagrams



Jumper Cap looks like this

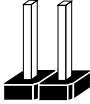

2 pin Jumper looks like this

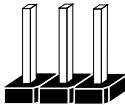

3 pin Jumper looks like this

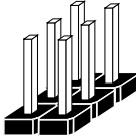
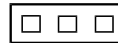

Jumper Block looks like this

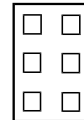

### Jumper settings



2 pin Jumper closed(enabled)  
looks like this



1

1

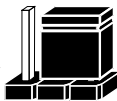

3 pin Jumper  
2-3 pin closed(enabled)  
looks like this



1

1



Jumper Block  
1-2 pin closed(enabled)  
looks like this

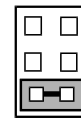

1 2

1 2

### 3.4 Main Board Connector & Jumper Quick Reference Table

JUMPER	NAME
USB Signal Selection	JP1, JP2
Cash Drawer Voltage Selection	JP3
Clear CMOS Data Selection	JPCMOS1

CONNECTOR	NAME
DC In Connector	DC In
1st Display Port	MDP1
COM Port RS-232 Connector	COM1, COM2
LAN Port Connector	LAN1
USB Type C Port	USB Type C
Dual USB 3.0 Ports	USB1
Dual USB 2.0 Ports	USB2
2nd Display Port	MDP2
HDMI Port Connector	HDMI1
Cash Drawer Port Connector	DRW
Internal USB Wafer	JUSB1, JUSB9
Internal USB Wafer	JUSB7 (co-lay with side I/O USB7)
Speaker Wafer	JSPK1
Microphone Connector	JMIC1
Power Output 24V Wafer	24V_OUT1
System LED Wafer	JSYS_LED1
CPU FAN Wafer	CPU_FAN1
Power Button Wafer	JPWRBTN1
Battery Wafer	JBAT1
System Reset Wafer	JRST1
M.2 M-Key Connector for SSD	M2_M1, M2_M2
M.2 E-Key Connector for Wi-Fi	M2_E1



### 3.5 Setting Main Board Connectors and Jumpers

#### 3.5.1 Power Switch

**Connector Location: Power Switch**

**Description:** To turn on the system, open up the cover from the right side of PA-J510 Box and press the power switch briefly.

ACTION	ASSIGNMENT
Click	0V
Release	+3.3V

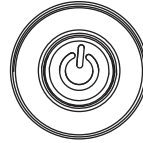

**Power Switch**

#### 3.5.2 DC IN Connector (DC In)

**Connector Location: DC In**

**Description:** Power In Connector

PIN	ASSIGNMENT	PIN	ASSIGNMENT
1	GND	2	GND
3	V24P0A_IN	4	V24P0A_IN

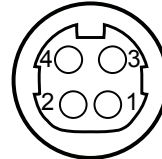

**DC In**

**3.5.3 1st Display Port (MDP1)**

**Connector Location: MDP1**

**Description: 1st Display Port**

**Proprietary Pin Assignment for Protech Original Display Only:**

PIN	ASSIGNMENT
1	GND
2	EDP_HPDP_C_A
3	DDIA_LANE0_DP_C
4	EDP_BKLT_EN_R
5	DDIA_LANE0_DN_C
6	EDP_BKLT_CTRL_R
7	GND
8	EDP_VDD_EN_R
9	DDIA_LANE1_DP_C
10	USB2_P3_DN_C
11	DDIA_LANE1_DN_C
12	USB2_P3_DP_C
13	HD_GND
14	GND
15	LINE-OUT-R
16	DDIA_AUX_DP_C
17	LINE-OUT-L
18	DDIA_AUX_DN_C
19	HD_GND
20	V24P0

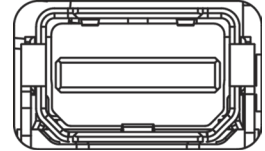

**MDP1**

**3.5.4 COM Ports (COM1, COM2)**

**Connector Location: COM1, COM2**

**Description: COM Ports, RJ11**

PIN	ASSIGNMENT
1	COM1/2_DCDJ_I
2	COM1/2_RX_I
3	COM1/2_TX_I
4	COM1/2_DTRJ_I
5	GND
6	COM1/2_DSRJ_I
7	COM1/2_RTSJ_I
8	COM1/2_CTSJ_I
9	COM1/2_RI_SEL
10	-

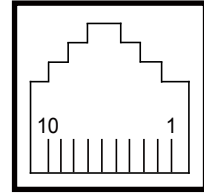

**COM1 /  
COM2**

**COM1, COM2 Voltage Adjustment**

The voltage of external ports "COM1 and COM2" is made to control on BIOS for your convenience.

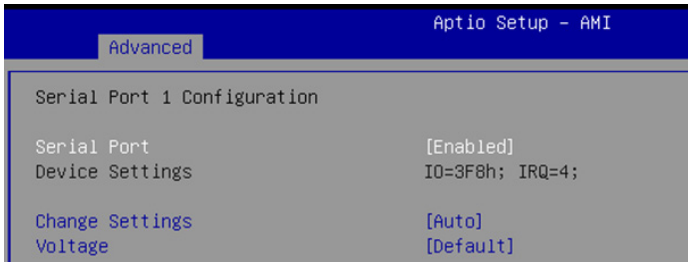

Please refer to the descriptions of **Serial Port 1** and **Serial Port 2 Configuration** under **Advanced > F81967 Super IO Configuration** menu in Chapter 5 BIOS Setup.

**3.5.5 LAN Port (LAN1)**

**Connector Location: LAN1**

**Description: LAN Port, RJ45**

PIN	ASSIGNMENT
R1	LAN1_MDIO_DP
R2	LAN1_MDIO_DN
R3	LAN1_MDII_DP
R4	LAN1_MDII_DN
R7	LAN1_MDII2_DP
R8	LAN1_MDII2_DN
R9	LAN1_MDII3_DP
R10	LAN1_MDII3_DN

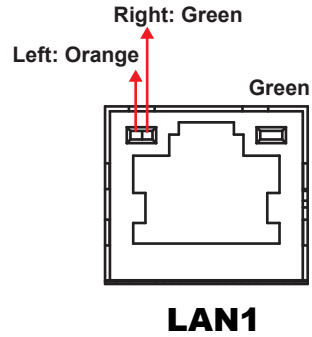

**LAN LED Indicator:**

**Left Side LED**

Orange Color Blinking	Giga LAN Message Active
Green Color Blinking	10/100Mbps LAN Message Active

**Right Side LED**

Green Color On	LAN switch / hub connected.
----------------	-----------------------------

**3.5.6 USB Type C Port (USB Type C)**

**Connector Location:** USB Type C

**Description:** USB Type C



**USB Type C**

<b>PIN</b>	<b>ASSIGNMENT</b>	<b>PIN</b>	<b>ASSIGNMENT</b>
A1	GND	B1	GND
A2	USB31_P3_TX_DP_R	B2	USB31_P4_TX_DP_R
A3	USB31_P3_TX_DN_R	B3	USB31_P4_TX_DN_R
A4	TYPEC_PWR	B4	TYPEC_PWR
A5	TP	B5	TP
A6	USB2_P4_DP_R	B6	USB2_P4_DP_R
A7	USB2_P4_DN_R	B7	USB2_P4_DN_R
A8	TP	B8	TP
A9	TYPEC_PWR	B9	TYPEC_PWR
A10	USB31_P4_RX_DN_R	B10	USB31_P3_RX_DN_R
A11	USB31_P4_RX_DP_R	B11	USB31_P3_RX_DP_R
A12	GND	B12	GND

**3.5.7 Dual USB 2.0 Ports (USB2)**

**Connector Location: USB2**

**Description:** USB 2.0 Type A Ports

**USB 2.0**

PIN	ASSIGNMENT	PIN	ASSIGNMENT
1	USB_PWR8	5	USB_PWR5
2	USB2_P8_DN	6	USB2_P5_DN
3	USB2_P8_DP	7	USB2_P5_DP
4	GND	8	GND

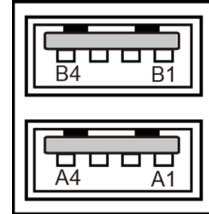

**USB2  
(USB2.0)**

**3.5.8 Dual USB 3.0 Ports (USB1)**

**Connector Location: USB1**

**Description:** USB 3.0 Type A Ports

**USB 3.0**

PIN	ASSIGNMENT	PIN	ASSIGNMENT
A1	USB_PWR1	B1	USB_PWR2
A2	USB2_P1_DN	B2	USB2_P2_DN
A3	USB2_P1_DP	B3	USB2_P2_DP
A4	GND	B4	GND
A5	USB31_P1_RX_DN	B5	USB31_P2_RX_DN
A6	USB31_P1_RX_DP	B6	USB31_P2_RX_DP
A7	GND	B7	GND
A8	USB31_P1_TX_DN	B8	USB31_P2_TX_DN
A9	USB31_P1_TX_DP	B9	USB31_P2_TX_DP

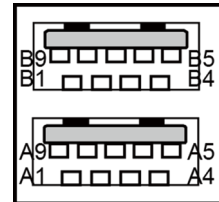

**USB1  
(USB3.0)**

**3.5.9 2nd Display Port (MDP2)**

**Connector Location: MDP2**

**Description: 2nd Display Port**

**Proprietary Pin Assignment for Protech Original Display Only:**

PIN	ASSIGNMENT
1	GND
2	EDP_HPDP_C_B
3	DDIB_LANE0_DP_C
4	2ND BKLT_EN
5	DDIB_LANE0_DN_C
6	2ND BKLT_CTRL
7	GND
8	2ND VDD_EN
9	DDIB_LANE1_DP_C
10	USB2_P6_DN_C
11	DDIB_LANE1_DN_C
12	USB2_P6_DP_C
13	GND
14	GND
15	NC
16	DDIB_AUX_DP_C
17	NC
18	DDIB_AUX_DN_C
19	GND
20	V24P0

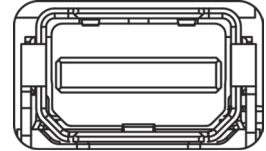

**MDP2**

**3.5.10 HDMI Port Connector (HDMI1)**

**Connector Location:** HDMI1

**Description:** Display Port Connector

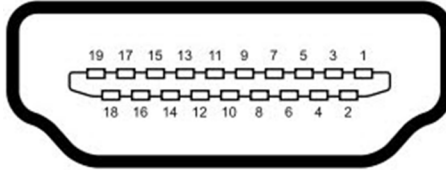

**HDMI1**

PIN	ASSIGNMENT	PIN	ASSIGNMENT
1	HDMI_P2	2	GND
3	HDMI_N2	4	HDMI_P1
5	GND	6	HDMI_N1
7	HDMI_P0	8	GND
9	HDMI_N0	10	HDMI_CLKP
11	GND	12	HDMI_CLKN
13	GND	14	GND
15	HDMI_SCL_5V	16	HDMI_SDA_5V
17	GND	18	V5P0S_HDM
19	HDMI_HPD	20	-



**3.5.11 Cash Drawer Port (DRW)**

**Connector Location: DRW**

**Description:** DRW is used by default. Adopt the method below:

PIN	ASSIGNMENT
1	COM2_DCDJ_I
2	COM2_RX_I
3	COM2_TX_I
4	COM2_DTRJ_I
5	GND
6	COM2_DSRJ_I

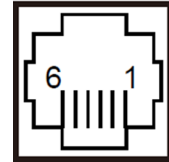

**DRW**

**Cash Drawer CONFIGURATION**

The I/O port address of the watchdog timer is 2E (hex) and 2F (hex). 2E (hex) is the address port. 2F (hex) is the data port. User must first assign the address of register by writing address value into address port 2E (hex), then write/read data to/from the assigned register through data port 2F (hex).

SIO Address	
Cash drawer Open	LDN06, 0x81, bit1
Cash drawer Status	LDN06, 0x81, bit0

## Configuration Sequence

To program F81967 configuration registers, the following configuration sequence must be followed:

### (1) Enter the extended function mode

To place the chip into the Extended Function Mode, two successive writes of 0x87 must be applied to Extended Function Enable Registers (EFERs, i.e. 2Eh or 4Eh).

### (2) Configure the configuration registers

The chip selects the Logical Device and activates the desired Logical Devices through Extended Function Index Register (EFIR) and Extended Function Data Register (EFDR). The EFIR is located at the same address as the EFER, and the EFDR is located at address (EFIR+1). First, write the Logical Device Number (i.e. 0x07) to the EFIR and then write the number of the desired Logical Device to the EFDR. If accessing the Chip (Global) Control Registers, this step is not required. Secondly, write the address of the desired configuration register within the Logical Device to the EFIR and then write (or read) the desired configuration register through the EFDR.

### (3) Exit the extended function mode

To exit the Extended Function Mode, writing 0xAA to the EFER is required. Once the chip exits the Extended Function Mode, it is in the normal running mode and is ready to enter the configuration mode.

**Code example for opening the cash drawer**

```
;----- Enter to extended function mode -----  
mov    dx,    2Eh  
mov    al,    87h  
out    dx,    al  
out    dx,    al  
;----- Select Logical Device 6 of Cash Drawer -----  
mov    al,    07h  
out    dx,    al  
inc    dx  
mov    al,    06h  
out    dx,    al  
;----- Open the Cash Drawer -----  
mov    al,    81h  
out    dx,    al  
inc    dx  
in     al,    dx  
or     al,    02h  
out    dx,    al  
;----- Close the Cash Drawer -----  
mov    al,    81h  
out    dx,    al  
inc    dx  
in     al,    dx  
and    al,    FDh  
out    dx,    al  
;----- Exit the extended function mode -----  
dec    dx  
mov    al,    AAh  
out    dx,    al
```

**3.5.12 Internal USB Wafer (JUSB1, JUSB9)**

**Connector Location: JUSB1, JUSB9**

**Description: Internal USB Wafer**

**JUSB1**

PIN	ASSIGNMENT
1	USB_PWR9
2	USB2_P9_DN
3	USB2_P9_DP
4	GND
5	GND

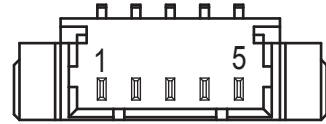

**JUSB1**

**JUSB9**

PIN	ASSIGNMENT
1	USB_PWR9
2	USB2_P9_DN
3	USB2_P9_DP
4	GND
5	GND

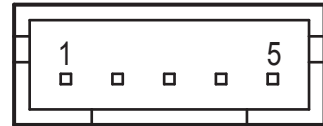

**JUSB9**

**3.5.13 Internal USB Wafer (JUSB7)**

**Connector Location: JUSB7**

**Description:** Internal USB Wafer (Co-lay with side I/O **USB7**)

**JUSB7**

PIN	ASSIGNMENT
1	5V
2	D-
3	D+
4	GND

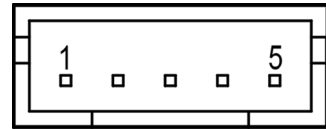

**JUSB7**

**3.5.14 M.2 M-Key Connector for SSD (M2\_M1)**

**Connector Location: M2\_M1**

**Description: M.2 M-Key Connector for SSD**

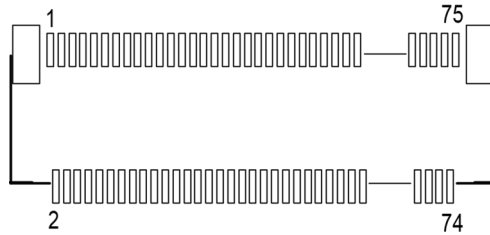

**M2\_M1**

PIN	ASSIGNMENT	PIN	ASSIGNMENT
2	V3P3S_M2_CPU	1	GND
4	V3P3S_M2_CPU	3	GND
6	NC	5	PCIE4_RX_N3
8	NC	7	PCIE4_RX_P3
10	M2_LED1	9	GND
12	V3P3S_M2_CPU	11	PCIE4_TX_N3
14	V3P3S_M2_CPU	13	PCIE4_TX_P3
16	V3P3S_M2_CPU	15	GND
18	V3P3S_M2_CPU	17	PCIE4_RX_N2
20	NC	19	PCIE4_RX_P2
22	NC	21	GND
24	NC	23	PCIE4_TX_N2
26	NC	25	PCIE4_TX_P2
28	NC	27	GND
30	NC	29	PCIE4_RX_N1
32	NC	31	PCIE4_RX_P1
34	NC	33	GND
36	NC	35	PCIE4_TX_N1
38	NC	37	PCIE4_TX_P1
40	NC	39	GND
42	NC	41	PCIE4_RX_N0 SATA1_RXP
44	NC	43	PCIE4_RX_P0 SATA1_RXN
46	NC	45	GND
48	NC	47	PCIE4_TX_N0 SATA1_TXN
50	M2_KEYM_CPU_SSD_RST_R_N	49	PCIE4_TX_P0 SATA1_TXP
52	GPPC_D5_SRCCLKREQ0_N	51	GND
54	WAKE_N	53	CLK_SRC0_DN

### Chapter 3 System Configuration

<b>PIN</b>	<b>ASSIGNMENT</b>	<b>PIN</b>	<b>ASSIGNMENT</b>
56	NC	55	CLK_SRC0_DP
58	NC	57	GND
60	NC	59	M_KEY
62	NC	61	M_KEY
64	NC	63	M_KEY
66	NC	65	M_KEY
68	NC	67	NC
70	V3P3S_M2_CPU	69	PCIE_SEL
72	V3P3S_M2_CPU	71	GND
74	V3P3S_M2_CPU	73	GND
-	-	75	GND

**3.5.15 M.2 M-Key Connector for SSD (M2\_M2)**

**Connector Location: M2\_M2**

**Description: M.2 M-Key Connector for SSD**

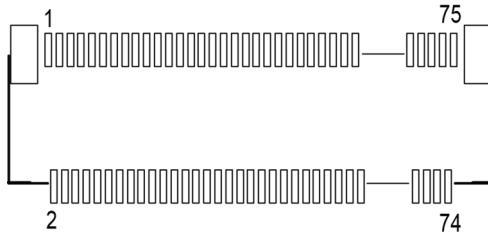

**M2\_M1**

PIN	ASSIGNMENT	PIN	ASSIGNMENT
2	V3P3S_M2_CPU	1	GND
4	V3P3S_M2_CPU	3	GND
6	NC	5	NC
8	NC	7	NC
10	M2_LED2	9	GND
12	V3P3S_M2_CPU	11	NC
14	V3P3S_M2_CPU	13	NC
16	V3P3S_M2_CPU	15	GND
18	V3P3S_M2_CPU	17	NC
20	NC	19	NC
22	NC	21	GND
24	NC	23	NC
26	NC	25	NC
28	NC	27	GND
30	NC	29	PCIE4_RX_N1
32	NC	31	NC
34	NC	33	NC
36	NC	35	NC
38	NC	37	NC
40	NC	39	GND
42	NC	41	SATA_0_RX_DP
44	NC	43	SATA_0_RX_DN
46	NC	45	GND
48	NC	47	SATA_0_TX_DN
50	M2_KEYM_CPU_SSD_RST_R_N	49	SATA_0_TX_DP
52	GPPC_D5_SRCCLKREQ0_N	51	GND
54	WAKE_N	53	CLK_SRC1_DN



### Chapter 3 System Configuration

<b>PIN</b>	<b>ASSIGNMENT</b>	<b>PIN</b>	<b>ASSIGNMENT</b>
56	NC	55	CLK_SRC1_DP
58	NC	57	GND
60	NC	59	M_KEY
62	NC	61	M_KEY
64	NC	63	M_KEY
66	NC	65	M_KEY
68	NC	67	NC
70	V3P3S_M2_1	69	NC
72	V3P3S_M2_1	71	GND
74	V3P3S_M2_1	73	GND
-	-	75	GND

**3.5.16 M.2 E-Key Connector for Wi-Fi (M2\_E1)**

**Connector Location: M2\_E1**

**Description:** M.2 E-Key Connector for Wi-Fi

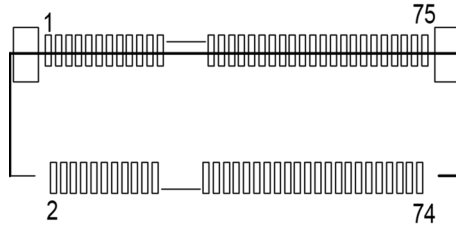

**M2\_E1**

PIN	ASSIGNMENT	PIN	ASSIGNMENT
2	V3.3A_WLAN	1	GND
4	V3.3A_WLAN	3	M_USB2_P10_DP
6	M2_WLAN_LED1_N	5	M_USB2_P10_DN
8	NC	7	GND
10	CNV_RF_RESET_N	9	CNVI_WR_D1N
12	NC	11	CNVI_WR_D1P
14	CRF_XTAL_CLKREQ	13	GND
16	M2_BT_LED2_N	15	CNVI_WR_D0N
18	GND	17	CNVI_WR_D0P
20	NC	19	GND
22	CNV_BRI_RSP	21	CNVI_WR_CLKN
24	E-KEY	23	CNVI_WR_CLKP
26	E-KEY	25	E-KEY
28	E-KEY	27	E-KEY
30	E-KEY	29	E-KEY
32	CNV_RGI_DT	31	E-KEY
34	CNV_RGI_RSP	33	GND
36	CNV_BRI_DT	35	PCIE3_P10_UFS_11_TX_DP
38	MLK_RST_N	37	PCIE3_P10_UFS_11_TX_DN
40	MLK_DATA	39	GND
42	MLK_CLK	41	PCIE3_P10_UFS_11_RX_DP
44	NC	43	PCIE3_P10_UFS_11_RX_DN
46	NC	45	GND
48	NC	47	CLK_SRC5_DP
50	SUS_CLK	49	CLK_SRC5_DN
52	M2_WLAN_PERST_R_N	51	GND
54	GPPC_A13_BT_RF_KILL_N	53	GPPC_H11_SRCCLKREQ5_N

### Chapter 3 System Configuration

<b>PIN</b>	<b>ASSIGNMENT</b>	<b>PIN</b>	<b>ASSIGNMENT</b>
56	GPPC_B15_WIFI_RF_KILL_N	55	GPPC_C23_WIFI_WAKE_N
58	NC	57	GND
60	NC	59	CNVI_WT_D1N
62	NC	61	CNVI_WT_D1P
64	TP11	63	GND
66	NC	65	CNVI_WT_D0N
68	NC	67	CNVI_WT_D0P
70	NC	69	GND
72	V3.3A_WLAN	71	CNVI_WT_CLKN
74	V3.3A_WLAN	73	CNVI_WT_CLKP
-	-	75	GND

**3.5.17 Speaker Wafer (JSPK1)**

**Connector Location: JSPK1**

**Description: Speaker Wafer**

PIN	ASSIGNMENT
1	VOUTP
2	VOUTN

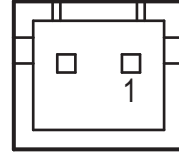

**JSPK1**

**3.5.18 Microphone Connector (JMIC1)**

**Connector Location: JMIC1**

**Description: Mic Pin Header**

PIN	ASSIGNMENT
1	HD_MIC1-R_L
2	HD_GND
3	HD_MIC1-L_L

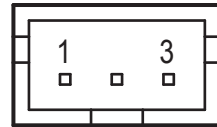

**JMIC1**

**3.5.19 Power Output 24V Wafer (J24V\_OUT1)**

**Connector Location: J24V\_OUT1**

**Description: Power Output 24V Wafer**

PIN	ASSIGNMENT
1	24V
2	24V
3	GND
4	GND

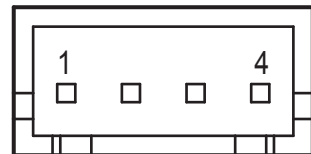

**J24V\_OUT1**

**3.5.20 System LED Wafer (JSYS\_LED1)**

**Connector Location:** JSYS\_LED1

**Description:** System LED Wafer

PIN	ASSIGNMENT
1	V5P0
2	GND

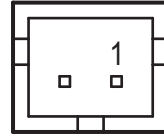

**JSYS\_LED1**

**3.5.21 CPU Fan Wafer (CPU\_FAN1)**

**Connector Location:** CPU\_FAN1

**Description:** CPU Fan Wafer

PIN	ASSIGNMENT
1	GND
2	V12P0
3	sense
4	Control



**CPU\_FAN1**

**3.5.22 Power Button Wafer (JPWRBTN1)**

**Connector Location: JPWRBTN1**

**Description: Power Button Wafer**

PIN	ASSIGNMENT
1	V3P3A
2	GND

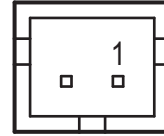

**JPWRBTN1**

**3.5.23 Battery Wafer (JBAT1)**

**Connector Location: JBAT1**

**Description: Battery Wafer**

PIN	ASSIGNMENT
1	VRTC_BATT
2	GND

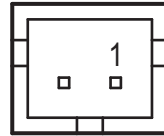

**JBAT1**

**3.5.24 System Reset Wafer (JRST1)**

**Connector Location: JRST1**

**Description: System Reset Wafer**

PIN	ASSIGNMENT
1	RST_SW
2	GND

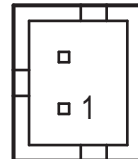

**JRST1**

**3.5.25 USB Signal Selection (JP1)**

**Jumper Location: JP1**

**Description:** USB Signal Selection

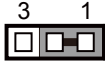
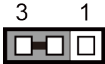
SELECTION	JUMPER SETTING	JUMPER ILLUSTRATION
M2_E1-USB2.0 D+ (for M2_E1)	1-2 (Default Setting)	 <p><b>JP1</b></p>
JUSB1-USB2.0 D+ (for JUSB1)	2-3	 <p><b>JP1</b></p>

**3.5.26 USB Signal Selection (JP2)**

**Jumper Location: JP2**

**Description:** USB Signal Selection

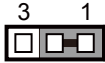
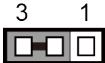
SELECTION	JUMPER SETTING	JUMPER ILLUSTRATION
M2_E1-USB2.0 D- (for M2_E1)	1-2 (Default Setting)	 <p><b>JP2</b></p>
JUSB1-USB2.0 D- (for JUSB1)	2-3	 <p><b>JP2</b></p>

**3.5.27 Cash Drawer Voltage Selection (JP3)**

**Jumper Location: JP3**

**Description:** Cash Drawer Voltage Selection

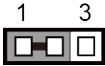
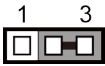

SELECTION	JUMPER SETTING	JUMPER ILLUSTRATION
24V	1-2 <i>(Default Setting)</i>	 <p><b>JP3</b></p>
12V	2-3	 <p><b>JP3</b></p>



**3.5.28 Clear CMOS Data Selection (JPCMOS1)**

**Jumper Location: JPCMOS1**

**Description:** Clear CMOS data selection

SELECTION	JUMPER SETTING	JUMPER ILLUSTRATION
Normal	Open <i>(Default Setting)</i>	 <b>JPCMOS1</b>
Clear CMOS Data	1-2	 <b>JPCMOS1</b>

**Note:** To clear CMOS data, you must power off the computer and set the jumper to “Clear CMOS” as illustrated above. After five to six seconds, set the jumper back to “Normal” and power on the computer.

### 3.6 A/D Board Component Locations & Jumper Setting

A/D Board: PR-J500

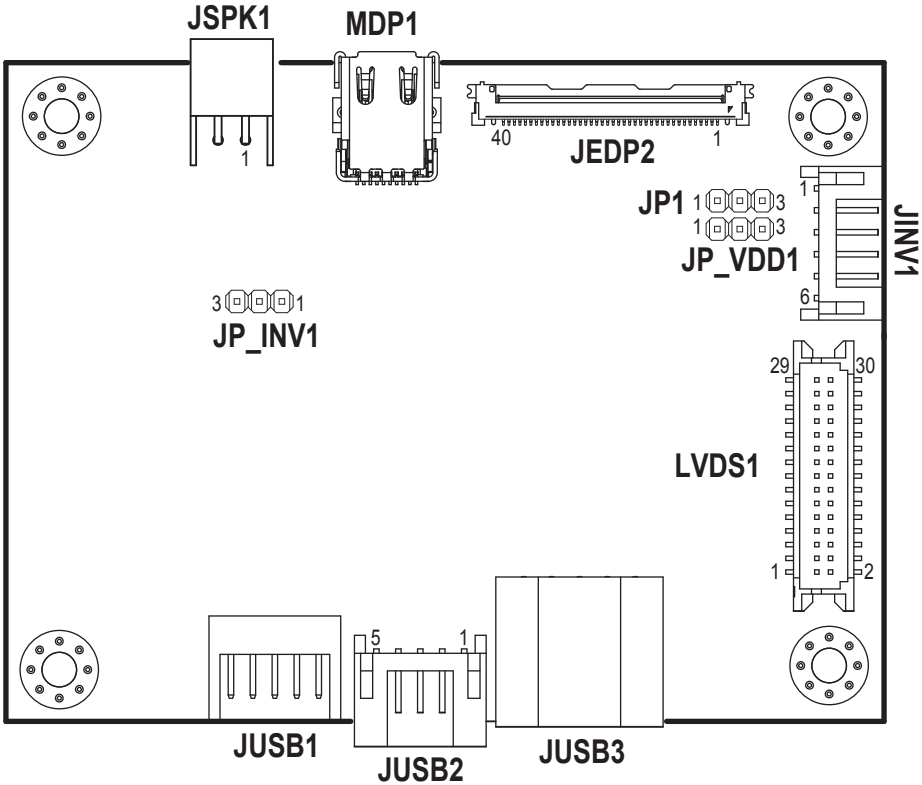

**3.7 A/D Board Connector & Jumper Quick Reference Table**

<b>JUMPER</b>	<b>NAME</b>
Backlight Voltage Selection	JP_INV1
LVDS Panel Voltage Selection	JP_VDD1
LVDS Backlight Control	JP1

<b>CONNECTOR</b>	<b>NAME</b>
1st Display Port Connector	MDP1
Embedded DisplayPort Connector	JEDP2
Speaker Connector	JSPK1
Inverter Connector	JINV1
LVDS Connector	LVDS1
USB 2.0 Connector	JUSB1, JUSB2, JUSB3

### 3.8 Setting A/D Board Connectors and Jumpers

#### 3.8.1 1st Display Port Connector (MDP1)

**Connector Location:** MDP1

**Description:** 1st Display Port Connector

**Proprietary Pin Assignment for Protech Original Display Only:**

PIN	ASSIGNMENT
1	GND
2	EDP_HPD_C_A
3	DDIA_LANE0_DP_C
4	EDP_BKLT_EN_R
5	DDIA_LANE0_DN_C
6	EDP_BKLT_CTRL_R
7	GND
8	EDP_VDD_EN_R
9	DDIA_LANE1_DP_C
10	USB2_P3_DN_C
11	DDIA_LANE1_DN_C
12	USB2_P3_DP_C
13	HD_GND
14	GND
15	LINE-OUT-R
16	DDIA_AUX_DP_C
17	LINE-OUT-L
18	DDIA_AUX_DN_C
19	HD_GND
20	V24P0

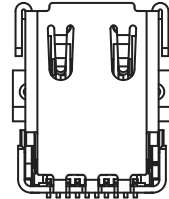

**MDP1**

**3.8.2 Embedded DisplayPort Connector (JEDP2)**

**Connector Location: JEDP2**

**Description:** Embedded DisplayPort Connector

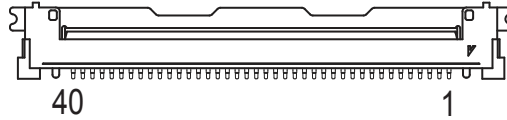

**JEDP2**

PIN	ASSIGNMENT	PIN	ASSIGNMENT
1	NC	21	LVDS_VDD
2	GND	22	EDP_SELF_TEST
3	NC	23	GND
4	NC	24	GND
5	GND	25	GND
6	NC	26	GND
7	NC	27	EDP_HPD
8	NGND	28	GND
9	EDP_LANE1_DN_C	29	GND
10	EDP_LANE1_DP_C	30	GND
11	GND	31	GND
12	EDP_LANE0_DN_C	32	EDP_BKLT_EN
13	EDP_LANE0_DP_C	33	DP_BKLT_CTRL
14	GND	34	EDP_DCR_EN
15	EDP_AUX_DN_C	35	NC
16	EDP_AUX_DP_C	36	INV_VCC
17	GND	37	INV_VCC
18	LVDS_VDD	38	INV_VCC
19	LVDS_VDD	39	INV_VCC
20	LVDS_VDD	40	NC

**3.8.3 Speaker Connector (JSPK1)**

**Connector Location: JSPK1**

**Description:** Speaker Connector

PIN	ASSIGNMENT
1	VOUTP
2	VOUTN

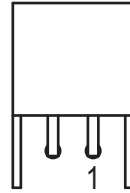

**JSPK1**

**3.8.4 Inverter Connector (JINV1)**

**Connector Location: JINV1**

**Description:** Inverter Connector

PIN	ASSIGNMENT
1	INV_VCC
2	INV_VCC
3	GND
4	LVDS_BKLCTL
5	GND
6	LVDS_BKLTEN

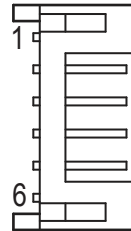

**JINV1**

**3.8.5 LVDS Connector (LVDS1)**

**Connector Location: LVDS1**

**Description: LVDS Connector**

PIN	ASSIGNMENT	PIN	ASSIGNMENT
1	LVDS_VDD	2	GND
3	LVDS_CLKB_DN	4	LVDS_CLKB_DP
5	GND	6	LVDS_B2_DN
7	LVDS_B2_DP	8	GND
9	LVDS_B1_DN	10	LVDS_B1_DP
11	LVDS_B3_DP	12	LVDS_B3_DN
13	LVDS_B0_DP	14	LVDS_B0_DN
15	GND	16	LVDS_CLKA_DP
17	LVDS_CLKA_DN	18	GND
19	LVDS_A2_DP	20	LVDS_A2_DN
21	GND	22	LVDS_A1_DP
23	LVDS_A1_DN	24	GND
25	LVDS_A0_DP	26	LVDS_A0_DN
27	LVDS_A3_DP	28	LVDS_A3_DN
29	LVDS_VDD	30	LVDS_VDD

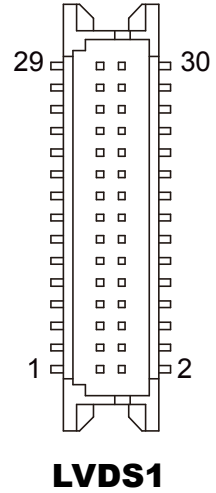

**3.8.6 USB 2.0 Connector (JUSB1, JUSB2, JUSB3)**

**Connector Location: JUSB1, JUSB2, JUSB3**

**Description: USB 2.0 Connector**

**JUSB1**

PIN	ASSIGNMENT	PIN	ASSIGNMENT
1	V5P0S_USB2	2	V5P0S_USB1
3	HUB1_DN2	4	HUB1_DN1
5	HUB1_DP2	6	HUB1_DP1
7	GND	8	GND
9	GND	10	GND

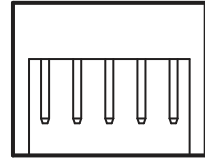

**JUSB1**

**JUSB2**

PIN	ASSIGNMENT
1	V5P0S_USB3
2	HUB1_DN3
3	HUB1_DP3
4	GND
5	GND

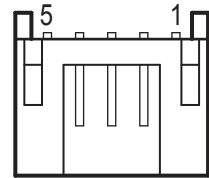

**JUSB2**

**JUSB3**

PIN	ASSIGNMENT
1	V5P0S_USB4
2	HUB1_DN42
3	HUB1_DP42
4	GND
5	GND



**JUSB3**



**3.8.7 Backlight Voltage Selection (JP\_INV1)**

**Jumper Location: JP\_INV1**

**Description:** Backlight Voltage Selection

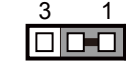
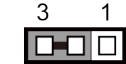
SELECTION	JUMPER SETTING	JUMPER ILLUSTRATION
5V (VIN_INV)	1-2 <i>(Default Setting)</i>	 <p><b>JP_INV1</b></p>
12V (VIN_INV)	2-3	 <p><b>JP_INV1</b></p>

**3.8.8 LVDS Panel Voltage Control Selection (JP\_VDD1)**

**Jumper Location: JP\_VDD1**

**Description:** LVDS Panel Voltage Control Selection

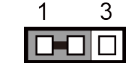
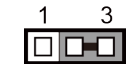
SELECTION	JUMPER SETTING	JUMPER ILLUSTRATION
3.3V (LVDS_VDD)	1-2 <i>(Default Setting)</i>	 <p><b>JP_VDD1</b></p>
5V (LVDS_VDD)	2-3	 <p><b>JP_VDD1</b></p>

**3.8.9 LVDS Backlight Control Selection (JP1)**

**Jumper Location: JP1**

**Description:** LVDS Backlight Control Selection

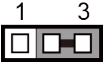
SELECTION	JUMPER SETTING	JUMPER ILLUSTRATION
3.3V (LVDS_BKLCTL)	1-2 <i>(Default Setting)</i>	 <p><b>JP1</b></p>
5V (LVDS_BKLCTL)	2-3	 <p><b>JP1</b></p>

# 4

## Software Utilities

---

---

This chapter provides the detailed information that guides users to install driver utilities. The following topics are included:

- Installing Intel® Chipset Software Installation Utility
- Installing Graphics Driver Utility
- Installing Intel® Management Engine Components Driver Installer
- Installing LAN Driver Utility
- Installing Intel® Serial I/O Driver Utility
- Installing Sound Driver Utility

## 4.1 Introduction

Enclosed with the PA-J510 Series package is our driver utilities, which comes in a DVD-ROM format. Refer to the following table for driver locations

### Windows 10 Enterprise 2016 LTSB\_64Bit

Filename (Assume that DVD-ROM drive is D :)	Purpose
D:\Driver\Platform\1_Main Chip\Win10(64-bit)	Intel(R) Chipset Device Software installer
D:\Driver\Platform\2_Graphics\Win10 (64-bit)	Intel(R) HD Graphics Driver installer
D:\Driver\Platform\3_ME\Win10 (64-bit)\	Intel(R) Management Engine Driver installer
D:\Driver\Platform\5_LAN Chip\Win10 (64-bit)	Intel(R) LAN Driver installer
D:\Driver\Platform\4_Serial IO\Win10 (64-bit)	Intel(R)Serial IO Driver installer
D:\Driver\Platform\6_sound\Win10 (64-bit)	Realtek(R) ALC888S HD Audio Driver installer

### 4.1.1 Installing Intel® Chipset Software Installation Utility

#### Introduction

The Intel® Chipset Software Installation Utility installs the Windows \*.INF files to the target system. These files outline to the operating system how to configure the Intel chipset components in order to ensure that the following functions work properly:

- SATA Storage Support (SATA & SATA II)
- USB Support (1.1 & 2.0)
- Identification of Intel® Chipset Components in Device Manager

#### Intel® Chipset Software Installation Utility

The utility pack is to be installed only for Windows 10 64Bit, and it should be installed immediately after the OS installation is finished. Please follow the steps below:

- 1** Connect the USB DVD-ROM device to PA-J510 and insert the driver disk.
- 2** Enter the “**Main Chip**” folder where the Chipset driver is located.
- 3** Select your Windows 10 platform.
- 4** Click “**SetupChipset.exe**” file for driver installation.
- 5** Follow the on-screen instructions to install the driver.
- 6** Once the installation is completed, shut down the system and restart PA-J510 for the changes to take effect.

### **4.1.2 Installing Graphics Driver Utility**

The GRAPHICS interface embedded in PA-J510 can support a wide range of display types. You can have dual displays via LCD and LVDS interfaces and make the system work simultaneously.

To install the Graphics driver utility, follow the steps below:

- 1** Connect the USB DVD-ROM device to PA-J510 and insert the driver disk.
- 2** Enter the “**Graphics**” folder where the driver is located
- 3** Select your Windows 10 platform.
- 4** Click the “**igxpin.exe**” file for Windows 10 platform for driver installation.
- 5** Follow the on-screen instructions to complete the installation.
- 6** Once the installation is completed, shut down the system and restart PA-J510 for the changes to take effect.

### **4.1.3 Intel® Management Engine Components Installer Installation**

To install the ME Driver, follow the steps below:

- 1** Connect the USB DVD-ROM device to PA-J510 and insert the driver disk
- 2** Enter the “**ME**” folder where the driver is located
- 3** Click “**SetupME.exe**” file for driver installation.
- 4** Follow the on-screen instructions to install the driver.
- 5** Once the installation is completed, shut down the system and restart PA-J510 for the changes to take effect.

#### 4.1.4 Installing LAN Driver Utility

Follow the steps below to install LAN Driver:

- 1 Go to **Computer Management** of your PC and select **Device Manager**.
- 2 Select **Network adapters > Intel® Ethernet Connection (13) I219-V**.
- 3 Enter “**D:\Driver\Platform\5\_LAN Chip\Win10 (64-bit)**” in the entry box to browse for LAN driver.
- 4 Click “**Next**” to continue and follow the on-screen instructions to install the driver.
- 5 Once the installation is completed, shut down the system and restart PA-J510 for the changes to take effect.

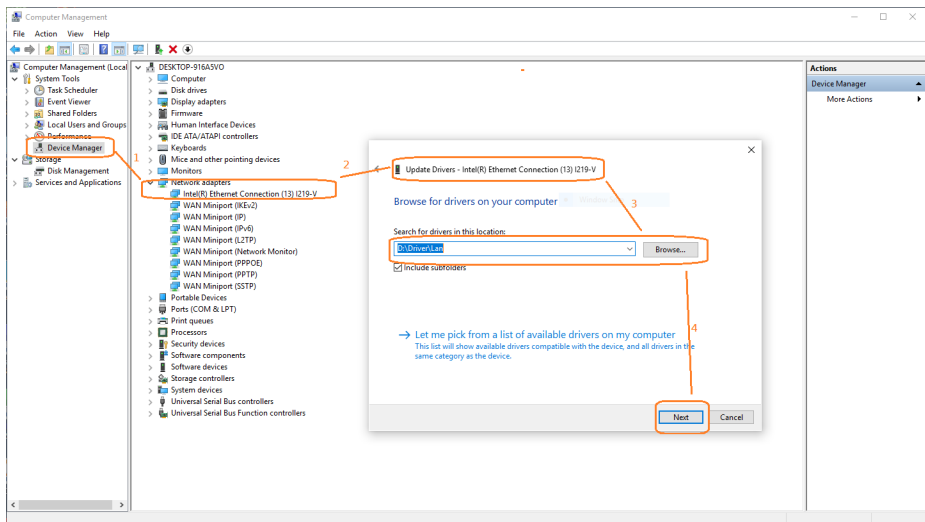

For more details on the installation procedure, refer to the **Readme.txt** file that you can find on LAN Driver Utility.



#### **4.1.5 Installing Intel® Serial I/O Driver Utility**

To install the Serial I/O Driver, follow the steps below:

- 1** Connect the USB DVD-ROM device to PA-J510 and insert the driver disk.
- 2** Open the “**Serial IO**” folder where the driver is located.
- 3** Click the “**SetupSerialIO.exe**” file for driver installation.
- 4** Follow the on-screen instructions to complete the installation.
- 5** Once the installation is completed, shut down the system and restart PA-J510 for the changes to take effect.

#### **4.1.6 Installing Sound Driver Utility**

The sound function enhanced in this system is fully compatible with Windows 10.

To install the Sound Driver, follow the steps below:

- 1** Connect the USB DVD-ROM device to PA-J510 and insert the driver disk.
- 2** Open the “**sound**” folder where the driver is located.
- 3** Click the “**Setup.exe**” file for driver installation.
- 4** Follow the on-screen instructions to complete the installation.
- 5** Once the installation is completed, shut down the system and restart PA-J510 for the changes to take effect.

# 5

## BIOS SETUP

---

This chapter guides users how to configure the basic system configurations via the BIOS Setup Utilities. The information of the system configuration is saved in BIOS NVRAM so that the Setup information is retained when the system is powered off. The BIOS Setup Utilities consist of the following menu items:

- Main Menu
- Advanced Menu
- Chipset Menu
- Security Menu
- Boot Menu
- Save & Exit Menu

## 5.1 Introduction

The **PA-J530** uses an AMI Aptio BIOS that is stored in the Serial Peripheral Interface Flash Memory (SPI Flash) and can be updated. The SPI Flash contains the BIOS Setup program, Power-on Self-Test (POST), the PCI auto-configuration utility, LAN EEPROM information, and Plug and Play support.

Aptio is AMI's BIOS firmware based on the UEFI (Unified Extensible Firmware Interface) Specifications and the Intel Platform Innovation Framework for EFI. The UEFI specification defines an interface between an operating system and platform firmware. The interface consists of data tables that contain platform-related information, boot service calls, and runtime service calls that are available to the operating system and its loader. These elements provide standard environment for booting an operating system and running pre-boot applications. The following diagram shows the Extensible Firmware Interface's location in the software stack.

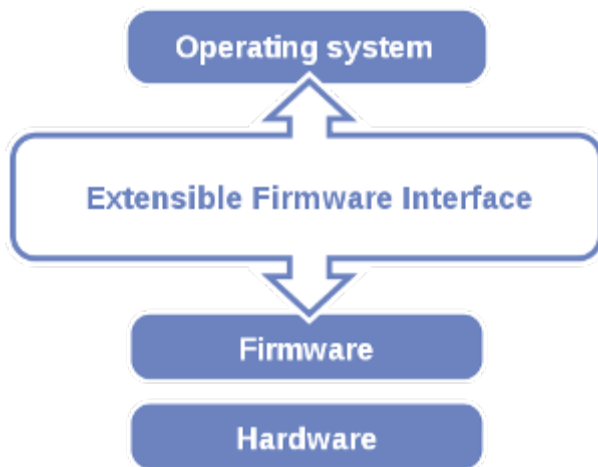

**Extensible Firmware Interface Diagram**

EFI BIOS provides an user interface allow users the ability to modify hardware configuration, e.g. change the system date and time, enable or disable a system component, decide bootable device priorities, setup personal password, etc., which is convenient for modifications and customization of the computer system and allows technicians another method for finding solutions if hardware has any problems.

The BIOS Setup program can be used to view and change the BIOS settings for the computer. The BIOS Setup program is accessed by pressing the <Del> or <ESC> key after the POST memory test begins and before the operating system boot begins. The settings are shown below.

Users will need to set up the system configuration from the BIOS Setup Utility when any of the following conditions occurs:

1. You are starting your system for the first time.
2. You have changed the hardware in your system or the hardware becomes faulty.
3. The system configuration is reset after the user configures to clear CMOS data via the JPCMOS1 jumper.
4. The power of the CMOS RAM became lost and the system configuration has been erased.

All the menu settings are described in details in this chapter.

### **5.1.1.1 Accessing Setup Utility**

When the system is powered on, the BIOS will enter the Power-On Self Test (POST) routines and the following message will appear on the lower screen:



**POST Screen with AMI Logo**

As long as this message is present on the screen you may press the <Del> key (the one that shares the decimal point at the bottom of the number keypad) to access the Setup program. In a moment, the main menu of the Aptio Setup Utility will appear on the screen:



### BIOS Setup Menu Initialization Screen

You may move the cursor by up/down keys to highlight the individual menu items. As you highlight each item, a brief description of the highlighted selection will appear at the bottom of the screen.

The language of the BIOS setup menu interface and help messages are shown in US English. You may use <↑> or <↓> key to select among the items and press <Enter> to confirm and enter the sub-menu. The following table provides the list of the navigation keys that you can use while operating the BIOS setup menu.

<b>BIOS Setup Navigation Key</b>	<b>Description</b>
<←> and <→>	Select a different menu screen (move the cursor from the selected menu to the left or right).
<↑> and <↓>	Select a different item (move the cursor from the selected item upwards or downwards)
<Enter>	Execute the command or select the sub-menu.
<F2>	Load the previous configuration values.
<F3>	Load the default configuration values.
<F4>	Save the current values and exit the BIOS setup menu.
<Esc>	Close the sub-menu. Trigger the confirmation to exit BIOS setup menu.



**5.1.2 Main**

Menu Path *Main*

The **Main** menu allows you to view the BIOS Information and change the system date and time. Use tab to switch between date elements. Use <↑> or <↓> arrow keys to highlight the item and enter the value you want in each item. This screen also displays the BIOS version (project) and BIOS Build Date and Time.

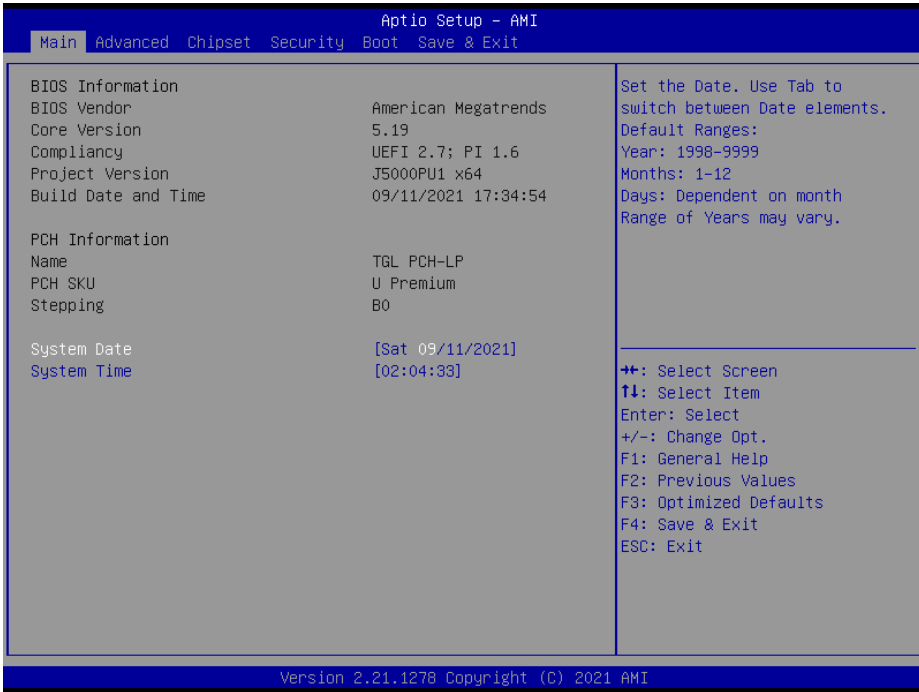

**BIOS Main Menu**

BIOS Setting	Options	Description/Purpose
BIOS Vendor	No changeable options	Displays the BIOS vendor.
Core Version	No changeable options	Displays the current BIOS core version.
Compliance	No changeable options	Displays the current UEFI version.
Project Version	No changeable options	Displays the version of the BIOS currently installed on the platform.
Build Date and Time	No changeable options	Displays the date of the current BIOS version.
Name	No changeable options	Displays the name of the PCH
PCH SKU	No changeable options	Displays the SKU for the PCH

BIOS Setting	Options	Description/Purpose
Stepping	No changeable options	Displays the stepping of the PCH
System Date	month, day, year	Sets the current date. The format is [Day Month/Date/ Year]. Users can directly enter values or use <+> or <-> arrow keys to increase/decrease it. The “Day” is automatically changed.
System Time	hour, minute, second	Sets the clock of the system. The format is [Hour: Minute: Second]. Users can directly enter values or use <+> or <-> arrow keys to increase/decrease it.

### 5.1.3 Advanced

Menu Path *Advanced*

This menu provides advanced the sub-menu items such as CPU Configuration, PCH-FW Configuration, Trusted Computing, ACPI Settings, F81967 Super IO Configuration, Hardware Monitor, F81967 Watchdog, USB Configuration and NVMe Configuration.

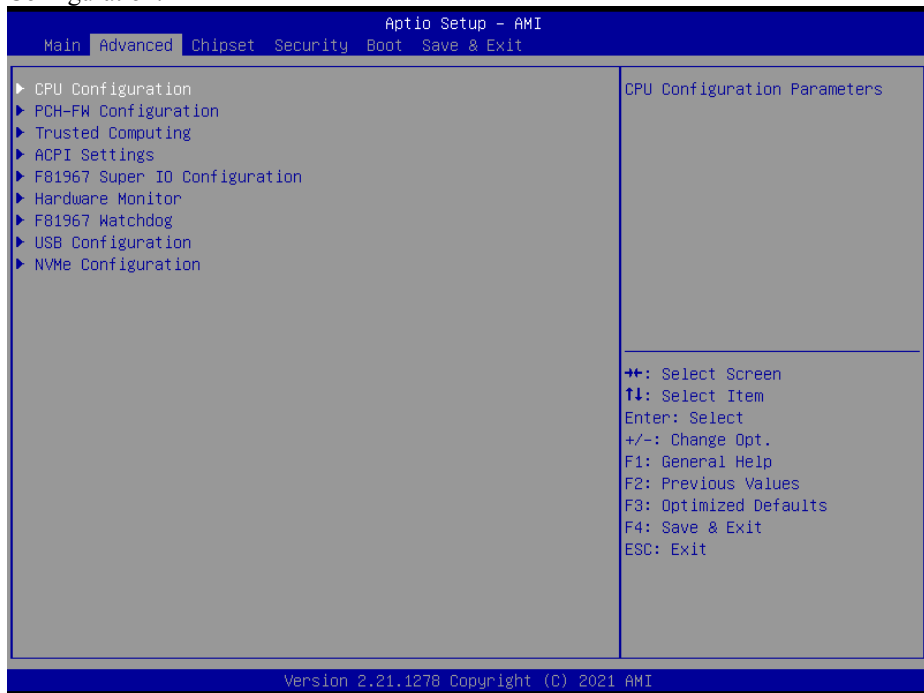

### BIOS Advanced Menu

<b>BIOS Setting</b>	<b>Options</b>	<b>Description/Purpose</b>
CPU Configuration	Sub-Menu	CPU Configuration Parameters.
PCH-FW Configuration	Sub-Menu	Management Engine Technology Parameters.
Trusted Computing	Sub-Menu	Trusted Computing Settings.
ACPI Settings	Sub-Menu	System ACPI Parameters.
F81967 Super IO Configuration	Sub-Menu	System Super IO Chip parameters.
Hardware Monitor	Sub-Menu	Monitor hardware status
F819676 Watchdog	Sub-Menu	F81967 Watchdog parameters
USB Configuration	Sub-Menu	USB Configuration Parameters.
NVMe Configuration	Sub-Menu	NVMe Device Options Settings.

5.1.3.1 Advanced - CPU Configuration

Menu Path *Advanced > CPU Configuration*

The **CPU Configuration** provides advanced CPU settings and some information about CPU.

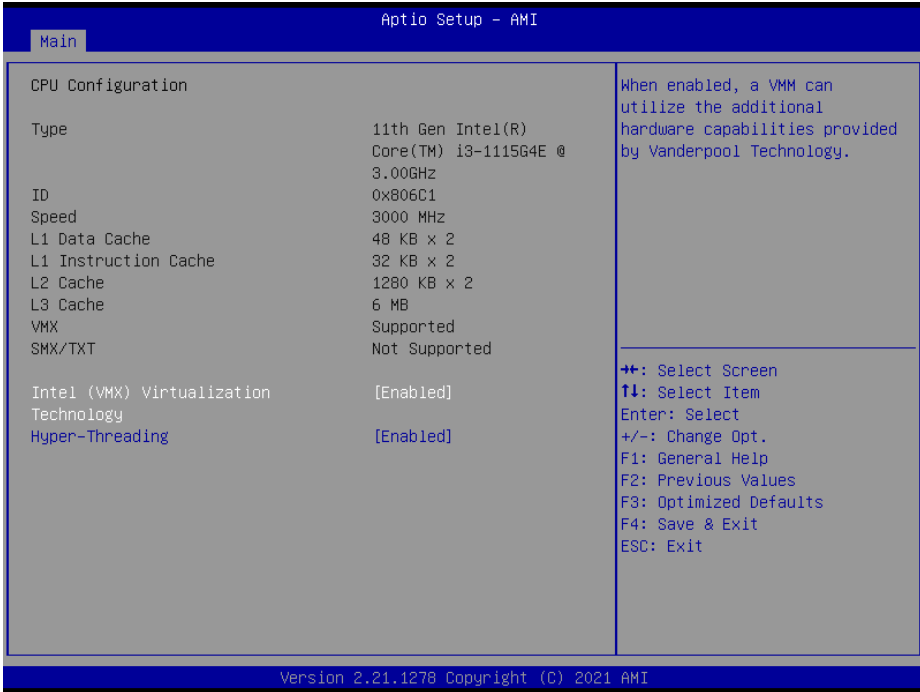

**CPU Configuration Screen**

BIOS Setting	Options	Description/Purpose
Type	No changeable options	Displays the CPU Type.
ID	No changeable options	Displays the CPU ID.
Speed	No changeable options	Displays the CPU Speed.
L1 Data Cache	No changeable options	Displays the size of L1 Data Cache
L1 Instruction Cache	No changeable options	Displays the size of L1 Instruction Cache
L2 Cache	No changeable options	Displays the size of L2 Cache.
L3 Cache	No changeable options	Displays the size of L3 Cache.
VMX	No changeable options	CPU/VMX hardware support for virtual machines.

BIOS Setting	Options	Description/Purpose
SMX/TXT	No changeable options	Secure Mode extensions support.
Intel (VMX) Virtualization Technology	- Disabled - Enabled (Default)	When enabled, VMM can utilize the additional hardware capabilities provided by Vanderpool Technology
Hyper-Threading	- Disabled - Enabled (Default)	When Disabled, only one thread per enabled core is enabled.

### 5.1.3.2 Advanced - PCH-FW Configuration

Menu Path *Advanced > PCH-FW Configuration*

The **PCH-FW** allows users to view the information about ME (Management Engine) firmware information, such ME firmware version, firmware mode and firmware SKU, and set PTT configuration.



**PCH-FW Configuration Screen**

BIOS Setting	Options	Description/Purpose
ME Firmware Version	No changeable options	Displays the ME Firmware Version.
ME Firmware Mode	No changeable options	Displays the ME Firmware Mode.
ME Firmware SKU	No changeable options	Displays the ME Firmware SKU.

**Advanced - PCH-FW Configuration - PTT Configuration**

Menu Path *Advanced > PCH-FW Configuration > PTT Configuration*



**PTT Configuration Screen**

BIOS Setting	Options	Description/Purpose
TPM Device Selection	- PTT (Default) - dTPM	Selects TPM device: PTT or dTPM.

**5.1.3.3 Advanced - Trusted Computing**

Menu Path *Advanced > Trusted Computing*

The **Trusted Computing** allows users to enable / disable BIOS support for security device. The operating system will now show Security Device. The TCG EFI protocol and INT1A interface will not be available.

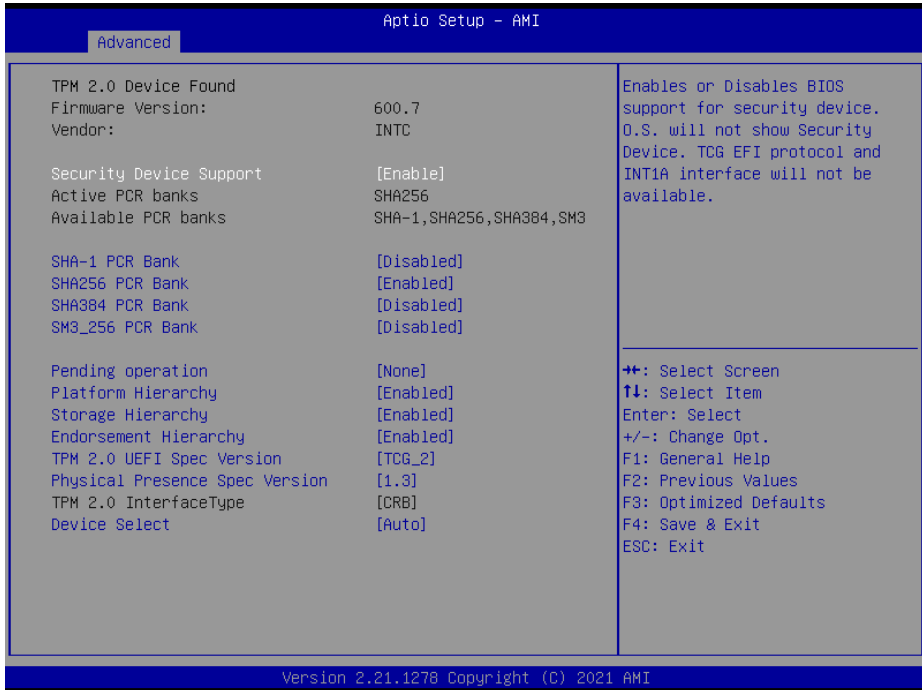

**Trusted Computing Screen**

\*Trusted Computing Screen function is for "CPU I5-7300U" SKU only.

BIOS Setting	Options	Description/Purpose
Firmware Version	No changeable options	Displays the Firmware Version.
Vendor	No changeable options	Displays the Vendor.
Security Device Support	- Disabled - Enabled (Defaults)	Enables or Disables BIOS support for security device. O.S. will not show Security Device. TCG EFI protocol and INT1A interface will not be available.
Active PCR banks	No changeable options	Displays the Active PCR banks.
Available PCR banks	No changeable options	Displays the Available PCR banks.
SHA-1 PCR Bank	- Disabled (Defaults) - Enabled	Enables or Disables SHA-1 PCR Bank.
SHA256 PCR Bank	- Disabled	Enables or Disables SHA256 PCR Bank.

BIOS Setting	Options	Description/Purpose
	- Enabled (Default)	
SHA384 PCR Bank	- Disabled (Default) - Enabled	Enables or Disables SHA384 PCR Bank.
SM3_256 PCR Bank	- Disabled (Default) - Enabled	Enables or Disables SM3_256 PCR Bank.
Pending operation	- None (Default) - TPM Clear	Schedules an Operation for the Security Device. NOTE: Your Computer will reboot during restart in order to change State of Security Device.
Platform Hierarchy	- Disabled - Enabled (Default)	Enables or Disables the Platform Hierarchy.
Storage Hierarchy	- Disabled - Enabled (Default)	Enabled or Disabled the Storage Hierarchy.
Endorsement Hierarchy	- Disabled - Enabled (Default)	Enabled or Disabled the Endorsement Hierarchy.
TPM2.0 UEFI Spec Version	- TCG_1_2 - TCG_2 (Default)	Selects the TCG2 Spec Version Support, TCG_1_2: the Compatible mode for Win8/Win10, TCG_2: Support new TCG2 protocol and event format for Win10 or later.
Physical Presence Spec Version	- 1.2 - 1.3 (Default)	Selects to Tell O.S to support PPI Spec Version 1.2 or 1.3. Note some HCK tests might not support 1.3.
TPM 2.0 InterfaceType	No changeable options	Display the TPM 20 InterfaceType.
Device Select	- TPM 1.2 - TPM 2.0 - Auto (Default)	TPM 1.2 will restrict support to TPM 1.2 devices, TPM 2.0 will restrict support to TPM 2.0 devices, Auto will support both with the default set to TPM 2.0 devices if not found, TPM 1.2 devices will be enumerated.



**5.1.3.4 Advanced - ACPI Settings**

Menu Path *Advanced > ACPI Settings*

The **ACPI Settings** allows users to configure relevant ACPI (Advanced Configuration and Power Management Interface) settings, such as enable / disable ACPI Auto Configuration, enable / disable Hibernation, ACPI Sleep State and S3 Video Repost.

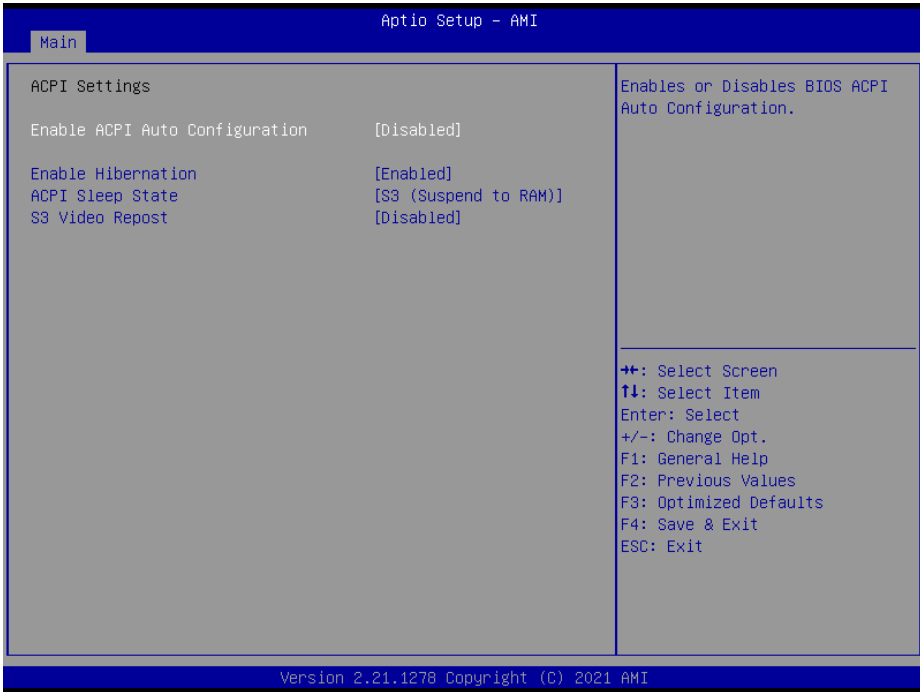

**ACPI Settings Screen**

BIOS Setting	Options	Description/Purpose
Enable ACPI Auto Configuration	- Disabled (Default) - Enabled	Enables or Disables BIOS ACPI Auto Configuration
Enable Hibernation	- Disabled - Enabled	Enables or disables the system’s ability to hibernate (OS / S4 Sleep State). This option may be not effective with some OS.
ACPI Sleep State	- Suspend Disabled - S3 (Suspend to RAM)	Selects the highest ACPI sleep state the system will enter when the SUSPEND button is pressed.
S3 Video Repost	- Disabled - Enabled	Enables or Disables S3 Video Repost.

**5.1.3.5 Advanced - F81967 Super IO Configuration**

Menu Path *Advanced > F81967 Super IO Configuration*

The **F81967 Super IO Configuration** allows users to configure the serial ports 1-2.



**F81967 Super IO Configuration Screen**

BIOS Setting	Options	Description/Purpose
Serial Port 1 Configuration	Sub-Menu	Configure the parameters of Serial Port 1 (COMA).
Serial Port 2 Configuration	Sub-Menu	Configure the parameters of Serial Port 2 (COMB).

**F81967 Super IO Configuration – Serial Port 1 Configuration**

Menu Path *Advanced > F81967 Super IO Configuration > Serial Port 1 Configuration*



**Serial Port 1 Configuration Screen**

BIOS Setting	Options	Description/Purpose
Serial Port	- Disabled - Enabled (Default)	Enables or disables Serial Port 1.
Device Settings	No changeable options	Displays the current settings of Serial Port 1.
Change Settings	- Auto (Default) - IO=3F8h; IRQ=4; - IO=3F8h; IRQ=3,4,5,6,7,10,11; - IO=2F8h; IRQ=3,4,5,6,7,10,11; - IO=3E8h; IRQ=3,4,5,6,7,10,11; - IO=2E8h; IRQ=3,4,5,6,7,10,11;	Selects IRQ and I/O resource settings for Serial Port 1.
Voltage	- RI (Default) - 5V - 12V	Selects COM port voltage

**F81967 Super IO Configuration – Serial Port 2 Configuration**

Menu Path *Advanced > F81967 Super IO Configuration > Serial Port 2 Configuration*

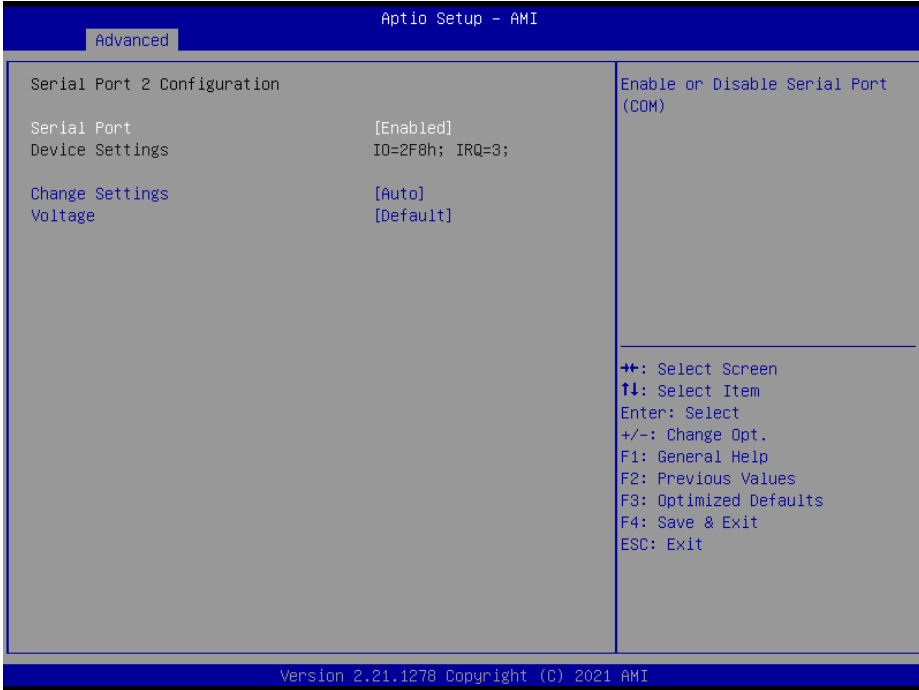

**Serial Port 2 Configuration Screen**

BIOS Setting	Options	Description/Purpose
Serial Port	- Disabled - Enabled	Enables or disables Serial Port 2.
Device Settings	No changeable options	Displays the current settings of Serial Port 2.
Change Settings	- Auto (Default) - IO=2F8h; IRQ=3; - IO=3F8h; IRQ=3,4,5,6,7,10,11; - IO=2F8h; IRQ=3,4,5,6,7,10,11; - IO=3E8h; IRQ=3,4,5,6,7,10,11; - IO=2E8h; IRQ=3,4,5,6,7,10,11;	Selects IRQ and I/O resource for the serial port 2.
Voltage	- RI (Default) - 5V - 12V	Selects COM port voltage

**5.1.3.6 Advanced - Hardware Monitor**

Menu Path *Advanced > Hardware Monitor*

The **Hardware Monitor** allows users to monitor the health and status of the system such as CPU temperature, system temperature, CPU fan speed, and voltage levels in supply.



**Hardware Monitor Screen**

BIOS Setting	Options	Description/Purpose
Smart Fan Mode Configuration	Sub-Menu	Smart Fan Mode Selection. <b>Note:</b> No CPU Fan is used on PA-J510.
CPU temperature	No changeable options	Displays the processor's temperature.
System temperature	No changeable options	Displays the system's temperature.
CPU Fan Speed	No changeable options	Displays CPU Fan speed. <b>Note:</b> Because no CPU Fan is used on PA-J510, so "N/A" is shown for this item.
VCCIN	No changeable options	Detects and displays the voltage level of VCCIN in supply.

<b>BIOS Setting</b>	<b>Options</b>	<b>Description/Purpose</b>
VCC3V	No changeable options	Detects and displays the voltage level of VCC3V in supply.
VS3V	No changeable options	Detects and displays the voltage level of VS3V in supply.
VCC5V	No changeable options	Detects and displays the voltage level of VCC5V in supply.
VS5V	No changeable options	Detects and displays the voltage level of VS5V in supply.
VCC12V	No changeable options	Detects and displays the voltage level of VCC12 in supply.
VBAT	No changeable options	Detects and displays the voltage level of VBAT in supply.

**Smart Fan Mode Configuration**

Menu Path *Advanced > Hardware Monitor > Smart Fan Mode Configuration*

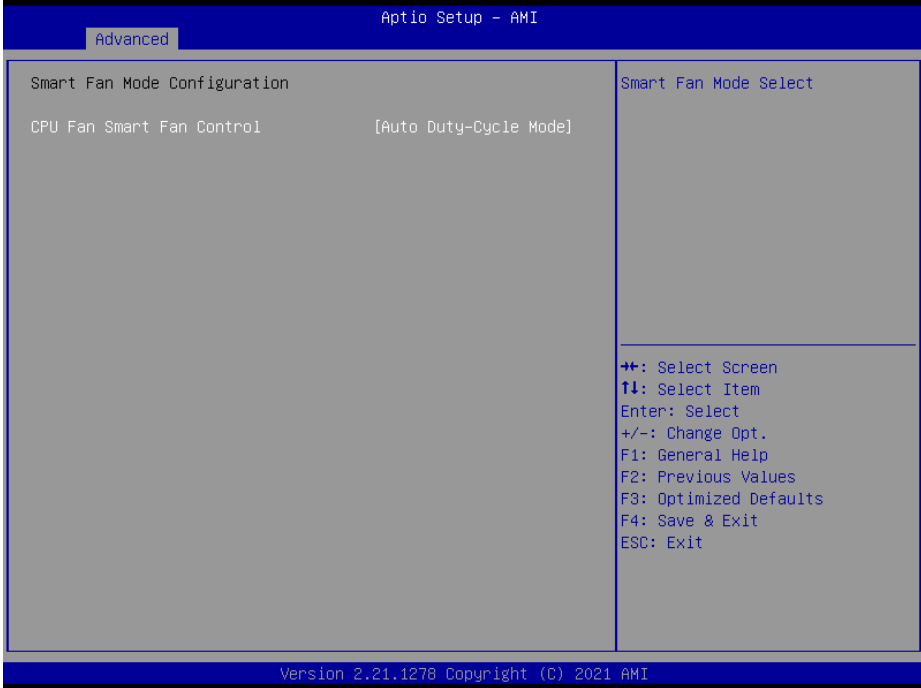

**Smart Fan Mode Configuration Screen**

BIOS Setting	Options	Description/Purpose
CPU Fan Smart Fan Control	- Manual Duty Mode - Auto Duty-Cycle Mode	Smart Fan Mode select for CPU Fan.
Manual Duty Mode	Numeric (from 1 to 100)	Manual mode fan control, user can write expected duty cycle (PWM fan type) 1-100.

**5.1.3.7 Advanced - F81967 Watchdog**

Menu Path *Advanced > F81967 Watchdog*

If the system hangs or fails to respond, enable the F81967 watchdog function to trigger a system reset via the 255-level watchdog timer.

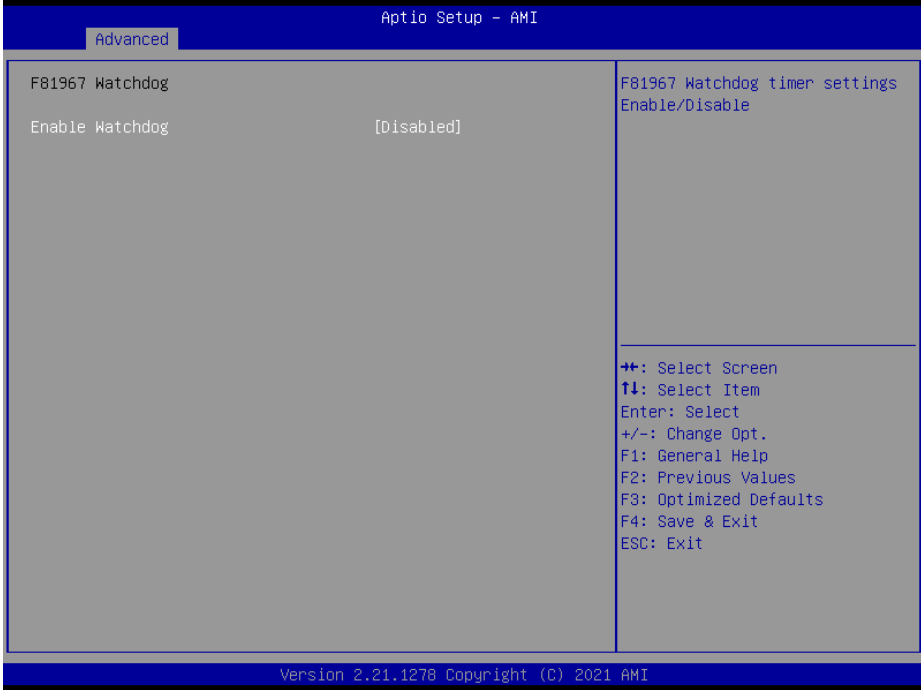

**F81967 Watchdog Screen**

BIOS Setting	Options	Description/Purpose
Enable Watchdog	- Enabled - Disabled (Default)	Enables / Disables F81967 Watchdog timer.
Watchdog Timer Count	Numeric (from 1 to 255)	The number of count for Timer.



**5.1.3.8 Advanced - USB Configuration**

Menu Path *Advanced > USB Configuration*

The **USB Configuration** allows users to configure advanced USB settings such as USB mass storage driver support.



**USB Configuration Screen**

BIOS Setting	Options	Description/Purpose
USB Module Version	No changeable options	Displays USB module version.
USB Controllers	No changeable options	Displays number and type of USB controllers (if any).
USB Devices	No changeable options	Displays number and type of connected USB devices (if any).
USB Mass Storage Driver Support	- Disabled - Enabled (Default)	Enables / Disables USB Mass Storage Driver Support.
Mass Storage Devices: [drive(s)]	- Auto (Default) - Floppy - Forced FDD - Hard Disk - CD-ROM	'AUTO' enumerates devices according to their media format. Optical drives are emulated as 'CD-ROM'. Drives with no media will be emulated according to a drive type.

**5.1.3.9 Advanced - NVMe Configuration**

Menu Path *Advanced > NVMe Configuration*

The **NVMe Configuration** allows users to view the information about NVMe Device.



**NVMe Configuration Screen**

BIOS Setting	Options	Description/Purpose
NVMe Configuration	No changeable options	Displays NVMe device.

**5.1.4 Chipset**

Menu Path *Chipset*

This menu allows users to configure advanced Chipset settings such as System Agent (SA) and PCH-IO configuration parameters.



**Chipset Menu Screen**

BIOS Setting	Options	Description/Purpose
System Agent (SA) Parameters	Sub-Menu	Sets the Parameter for System Agent (SA) configuration.
PCH-IO Configuration	Sub-Menu	Sets the Parameter for PCH configuration.

**5.1.4.1 System Agent (SA) Configuration**

Menu Path *Chipset > System Agent (SA) Configuration*

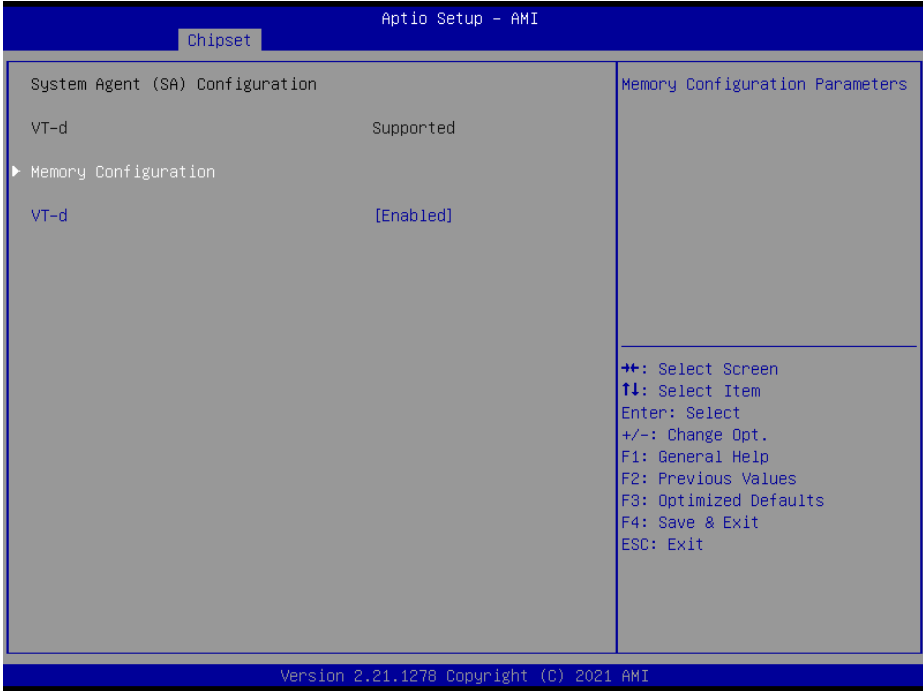

**System Agent (SA) Configuration Screen**

BIOS Setting	Options	Description/Purpose
Memory Configuration	Sub-Menu	Memory Configuration parameters
VT-d	- Disabled - Enabled (Default)	Enables or Disables VT-d function.

**System Agent (SA) Configuration – Memory Configuration**

Menu Path *Chipset > System Agent (SA) Configuration > Memory Configuration*

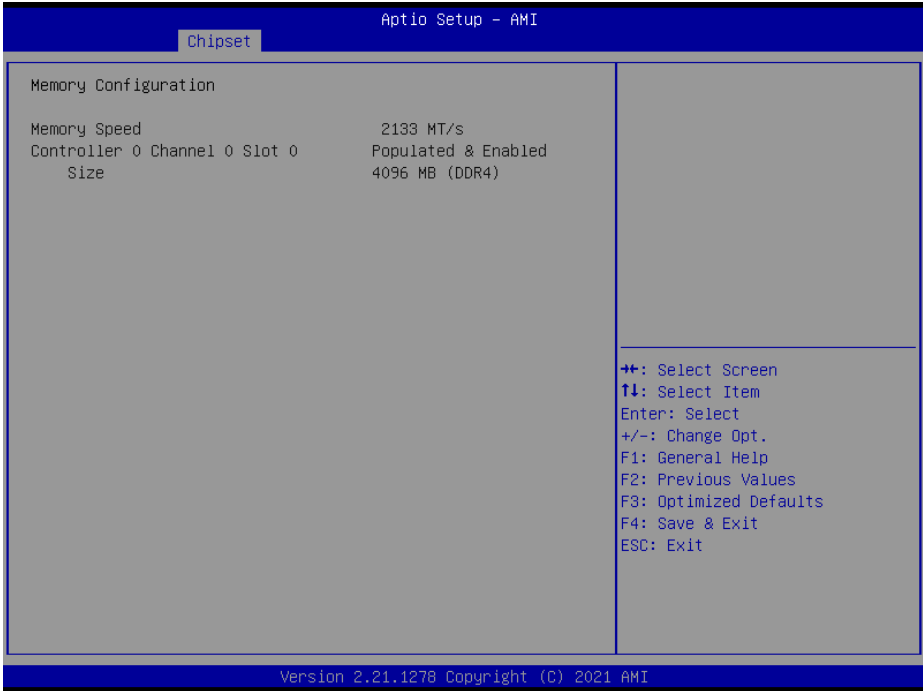

**Memory Configuration Screen**

BIOS Setting	Options	Description/Purpose
Memory Speed	No changeable options	Displays the Frequency of Memory.
Controller 0 Channel 0 Slot 0	No changeable options	Display the Controller 0 Channel 0 Slot 0 Subtitle.
Size	No changeable options	Displays the size of Controller 0 Channel 0 Slot 0.

**5.1.4.2 PCH IO Configuration**

Menu Path *Chipset > PCH IO Configuration*

The **PCH-IO Configuration** allows users to configure SATA and RST settings, enable/disable PCH LAN Controller and Wake-On-LAN function and determine the power on/off state that the system will go to following a power failure (G3 state).

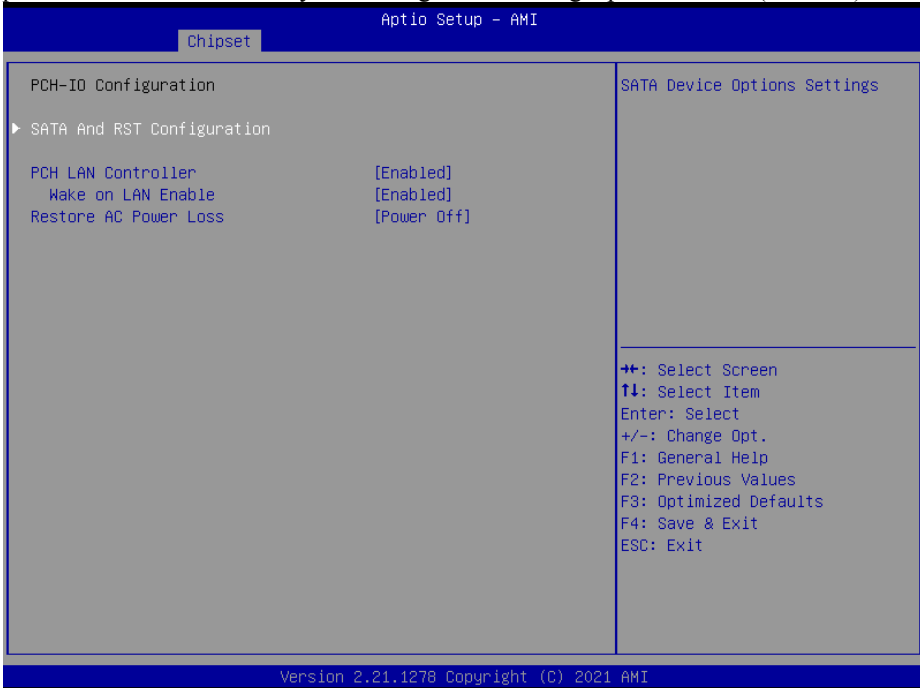

**PCH-IO Configuration Screen**

BIOS Setting	Options	Description/Purpose
SATA And RST Configuration	Sub-Menu	SATA and RST Configuration settings.
PCH LAN Controller	- Disabled - Enabled (Default)	Enables or Disables onboard NIC.
Wake On LAN Enable	- Disabled - Enabled (Default)	Enables or Disables integrated LAN to wake the system.
Restore AC Power Loss	- Power On - Power Off (Default)	Specifies what state to go to when power is re-applied following a power failure (G3 state).

**PCH-IO Configuration – SATA And RST Configuration**

Menu Path *Chipset > PCH-IO Configuration > SATA And RST Configuration*

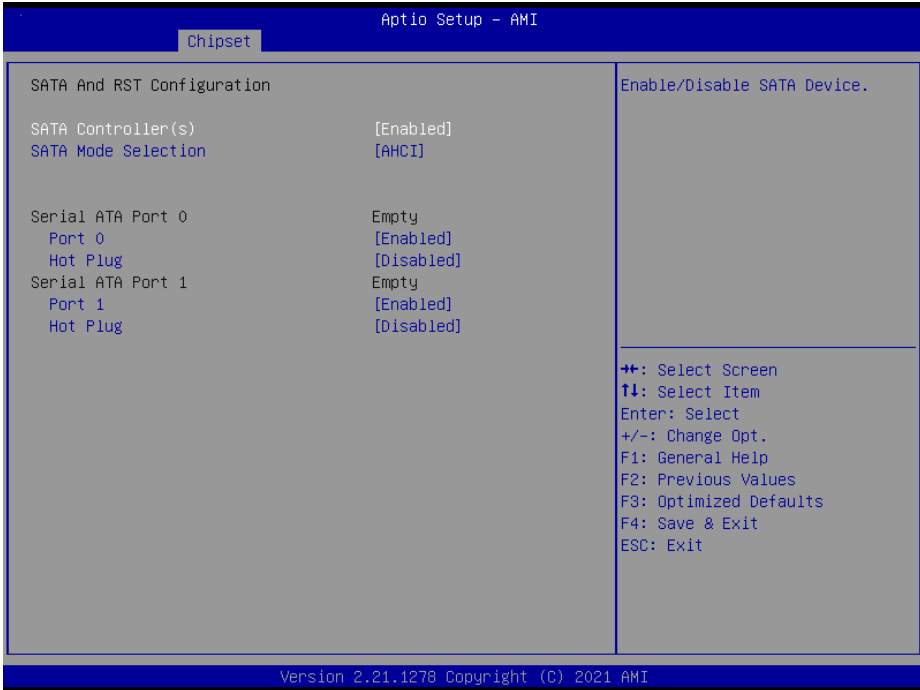

**SATA And RST Configuration Screen**

BIOS Setting	Options	Description/Purpose
SATA Controller(s)	- Disabled (Default) - Enabled	Enables or Disables SATA Device.
SATA Mode Selection	- AHCI (Default) - Intel RST Premium With Intel Optane System Acceleration (RAID)	Determines how SATA controller(s) operate.
Serial ATA Port 0 – 1	No changeable options	Displays the SATA device’s name.
Port 0 - 1	- Disabled - Enabled (Default)	Enable or Disable SATA Port Device.
Hot Plug	- Disabled (Default) - Enabled	Enable or Disable SATA Port Device Hot Plug function.

**5.1.5 Security**

Menu Path *Security*

From the **Security** menu, you are allowed to create, change or clear the administrator password. You will be asked to enter the configured administrator password before you can access the Setup Utility.

By setting an administrator password, you will prevent other users from changing your BIOS settings. You can configure an Administrator password and then configure a user password. An administrator has much more privileges over the settings in the Setup utility than a user. Heed that a user password does not provide access to most of the features in the Setup utility.

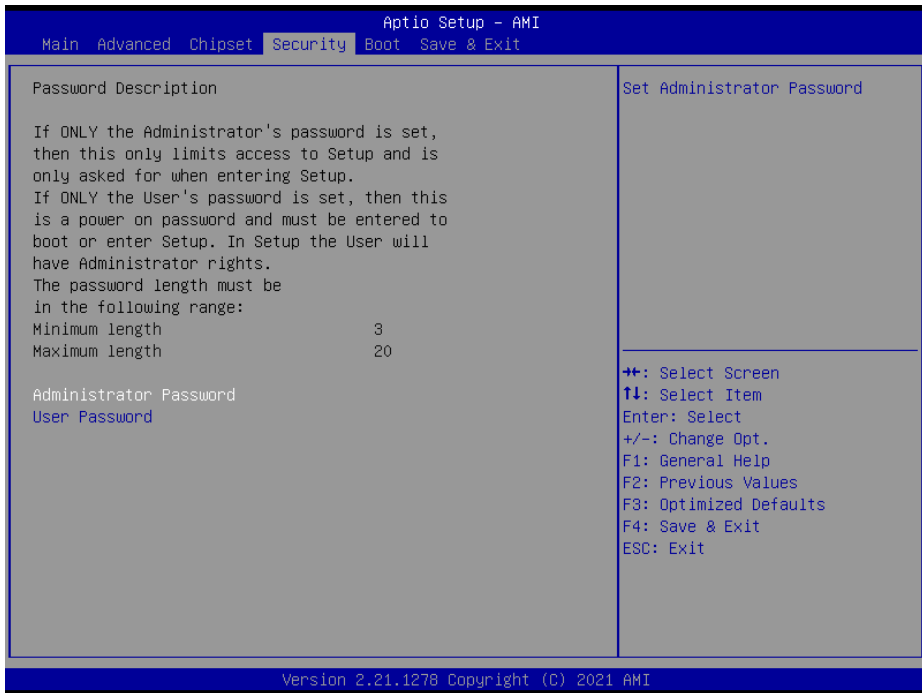

**Security Menu Screen**

BIOS Setting	Options	Description/Purpose
Administrator Password	Password can be 3-20 alphanumeric characters.	Specifies the administrator password.
User Password	Password can be 3-20 alphanumeric characters.	Specifies the user password.



### **Create an Administrator or User Password**

1. Select the **Administrator Password / User Password** option from the Security menu and press <Enter>, and the password dialog entry box appears.
2. Enter the password you want to create. A password can be 3-20 alphanumeric characters.  
After you have configured the password, press <Enter> to confirm.
3. Type the new password again and press <Enter>.

### **Change an Administrator or User Password**

1. Select the **Administrator Password / User Password** option from the Security menu and press <Enter>, and the password dialog entry box appears.
2. Select the Administrator Password or User Password that you want to change. A password can be 3-20 alphanumeric characters. After you have changed the password, press <Enter> to confirm.
3. Type the changed password again and press <Enter>.

### **Remove an Administrator or User Password**

1. Select the **Administrator Password / User Password** option from the Security menu and press <Enter>, and the password dialog entry box appears.
2. Select the configured Administrator Password or User Password that you want to delete.  
Leave the dialog box blank and press <Enter>.
3. Press <Enter> again when the password confirmation box appears.

**5.1.6 Boot**

Menu Path *Boot*

This menu provides control items for system boot configuration such as setting setup prompt timeout, enabling/disabling quiet boot and fast boot, changing the boot order from the available bootable device(s) and Screen Rotation policy.

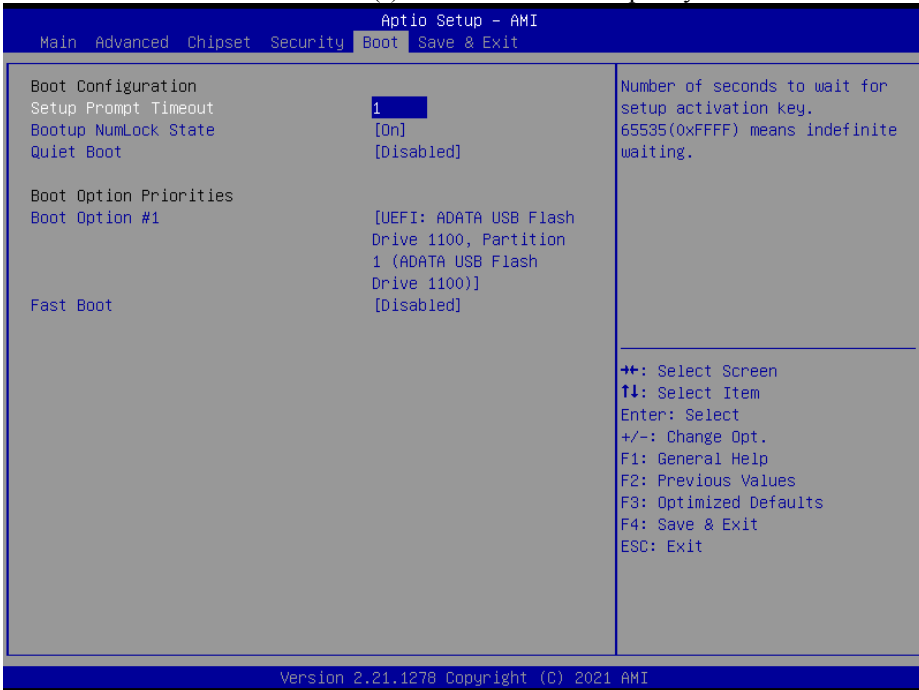

**Boot Menu Screen**

BIOS Setting	Options	Description/Purpose
Setup Prompt Timeout	Numeric (from 1 to 65535)	Number of seconds to wait for setup activation key.
Bootup NumLock State	- On (Default) - Off	Selects the NumLock state after the system is powered on. <ul style="list-style-type: none"> <li>• <b>On:</b> Enable the NumLock function automatically after the system is powered on.</li> <li>• <b>Off:</b> Disable the NumLock function after the system is powered on.</li> </ul>
Quiet Boot	- Disabled (Default) - Enabled	Enables or Disables Quiet Boot options.

<b>BIOS Setting</b>	<b>Options</b>	<b>Description/Purpose</b>
Fast Boot	- Disabled (Default) - Enabled	Enables or Disables Fast Boot options.
Boot Option #1~#n	- [Drive(s)] - Disabled	Sets the system boot order.

## 5.1.7 Save & Exit

Menu Path *Save & Exit*

The **Save & Exit** allows users to save or discard changed BIOS settings as well as load factory default settings.

### Save Changed BIOS Settings

To save and validate the changed BIOS settings, select **Save Changes** from the **Save & Exit** menu, or you can select **Save Changes and Exit** (or press **F4**) to validate the changes and then exit the system. Select **Save Changes and Reset** to validate the changed BIOS settings and then restart the system

### Discard Changed BIOS Settings

To cancel the BIOS settings you have previously configured, select **Discard Changes and Exit** from this menu, or simply press **Esc** to exit the BIOS setup. You can also select **Discard Changes and Reset** to discard any changes you have made and restore the factory BIOS defaults.

### Load User Defaults

You may simply press **F3** at any time to load the **Optimized Values** which resets all BIOS settings to the factory defaults.

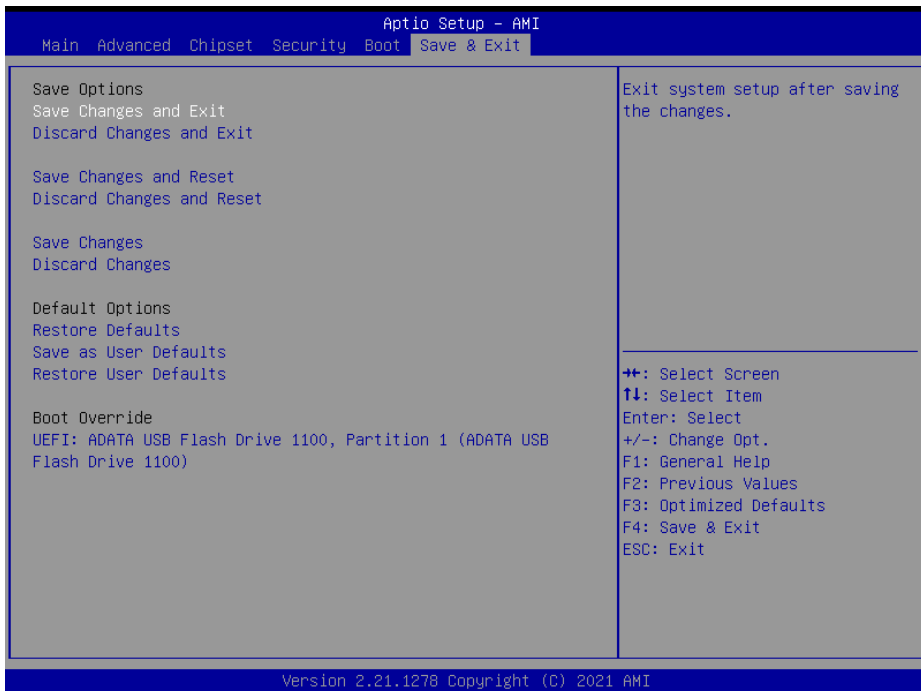

Save & Exit Menu Screen

<b>BIOS Setting</b>	<b>Options</b>	<b>Description/Purpose</b>
Save Changes and Exit	No changeable options	Exits and saves the changes in NVRAM.
Discard Changes and Exit	No changeable options	Exits without saving any changes made in BIOS settings.
Save Changes and Reset	No changeable options	Saves the changes in NVRAM and resets.
Discard Changes and Reset	No changeable options	Resets without saving any changes made in BIOS settings.
Save Changes	No changeable options	Saves Changes done so far to any of the setup options.
Discard Changes	No changeable options	Discards Changes done so far to any of the setup options.
Restore Defaults	No changeable options	Loads the optimized defaults for BIOS settings.
Save as User Defaults	No changeable options	Saves the changes done so far as User Defaults.
Restore User Defaults	No changeable options	Restores the User Defaults to all the setup options.
Boot Override	- [Drive(s)]	Forces to boot from selected [drive(s)].

# Appendix A System Diagrams

---

---

This appendix includes the easy maintenance diagrams, exploded diagrams of the system and the parts list as well as the part numbers of the PA-J510 system.

- PPC Memory Maintenance
- PPC M.2 2280 Maintenance
- PA-J510 Memory Maintenance
- PA-J510 M.2 2280 Maintenance
- How To Turn System Touchscreen
- 2nd Display Assembly
- VFD Module Assembly
- iButton Module Assembly
- Fingerprint Module Assembly
- Barcode Scanner Module Assembly
- MSR Module Assembly
- POS Type Assembly Exploded Diagram
- PPC Type Assembly Exploded Diagram

## PPC Memory Maintenance

**Step 1:** Release the 2 screws and unplug the DP cable from the I/O Ports.

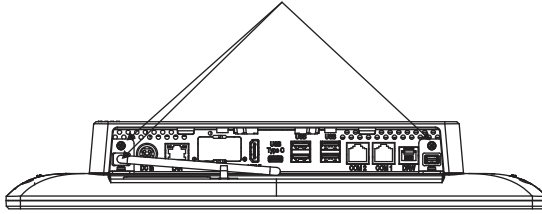

**Step 2:** Follow the directions (red arrows) below to separate the PCB Box from the touchscreen of Panel PC.

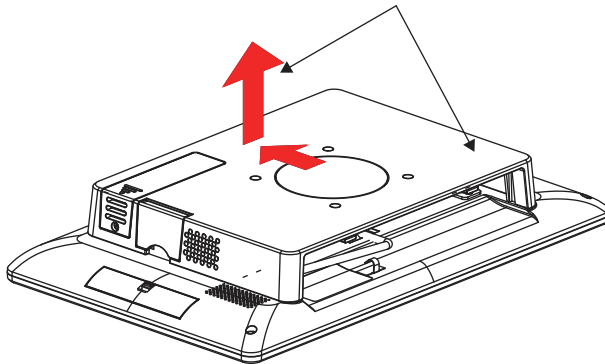

**Step 3:** Unfasten 5 screws as shown:

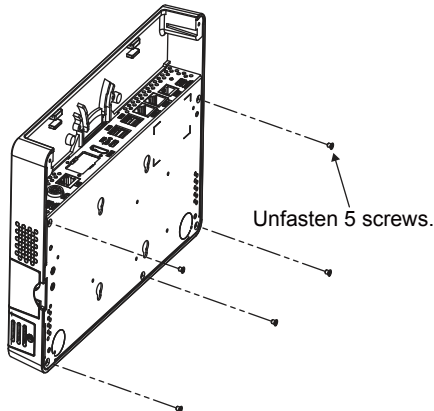

(continued on the next page)

**Step 4:** Move the PCB box outwards slightly as shown (red arrow) and lay the PCB box down on a flat surface.

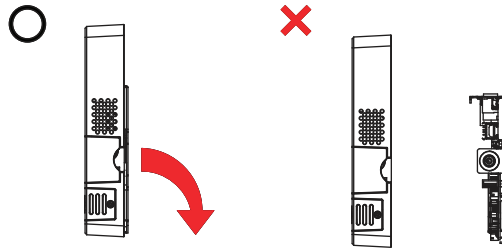

**Warning:** If you force to move the PCB Box too far away from PPC, the connected cables inside could be damaged.

**Step 5:** Open the cover and unplug all the connected cables.

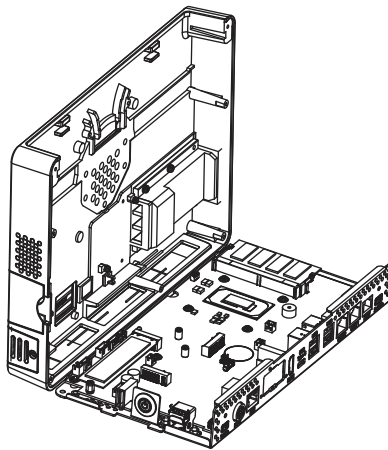

**Step 6:** Change the memory and heating pad.

**Step 7:** Re-connect all the unplugged cables and replace all removed screws in the order you dismantled and complete.



## **PPC M.2 2280 Maintenance**

**Step 1:** Unscrew M.2 2280 and follow the direction (red arrow) to release the cover.

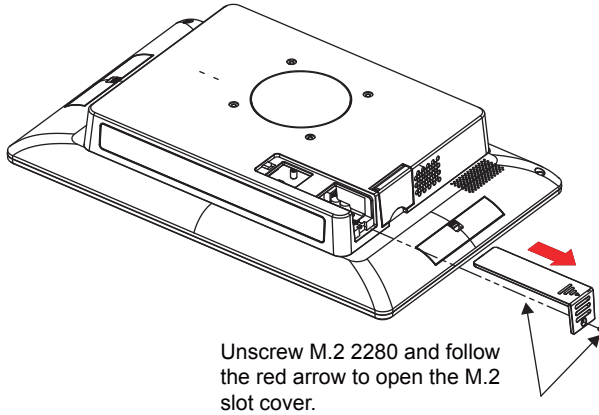

**Step 2:** Slide a new M.2 2280 into the M2. slot and fasten up the screw to secure the cover and complete.

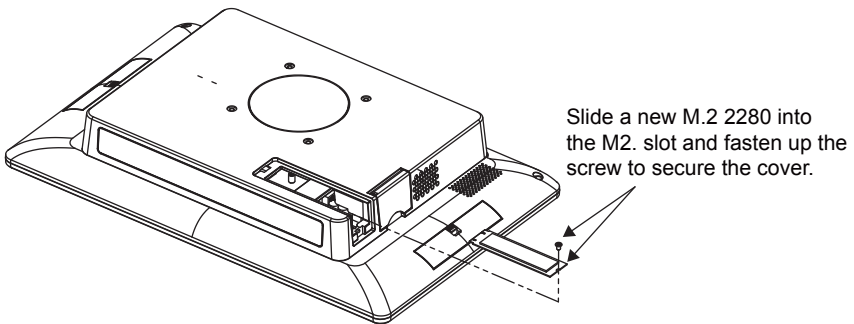

## PA-J510 Memory Maintenance

**Step 1:** Unplug the 2 Display Port cables from I/O Ports (1st Dis. and 2nd Dis. ports).

**Step 2:** Unfasten the 4 screws as shown:

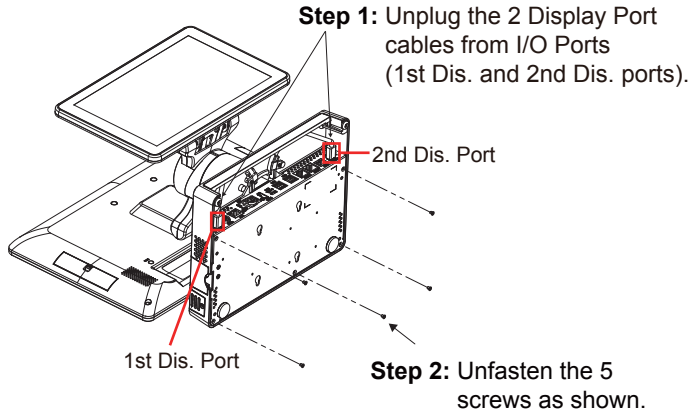

**Step 3:** Move the PCB box outwards slightly as shown (red arrow) and lay the PCB box down on a flat surface.

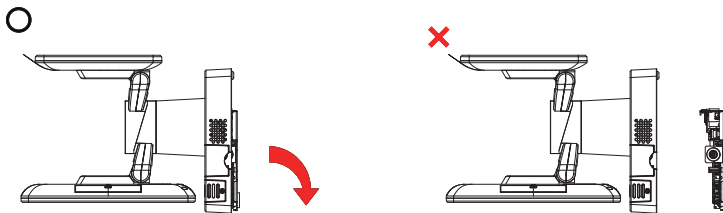

**Warning:** If you force to move the PCB Box too far away from the POS system, the connected cables inside the system could be damaged.

**Step 4:** Open the cover and unplug all the connected cables. (Remove the LED cable and Wi-Fi antenna if Wi-Fi function is available.)

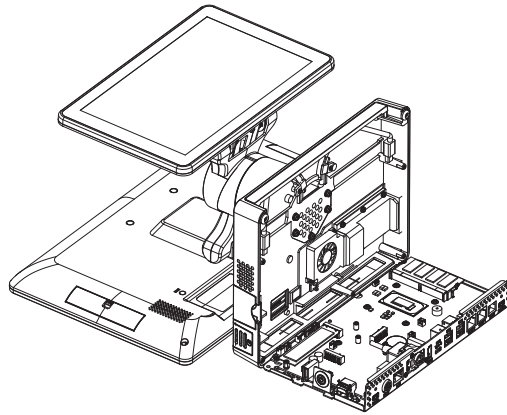

**Step 5:** Change the memory and heating pad.

**Step 6:** Re-connect all the unplugged cables and replace all removed screws in the order you dismantled.

**The memory replacement has been finished.**

## **PA-J510 M.2 2280 Maintenance**

**Step 1:** Follow the orange arrow to turn the system touchscreen leftwards.

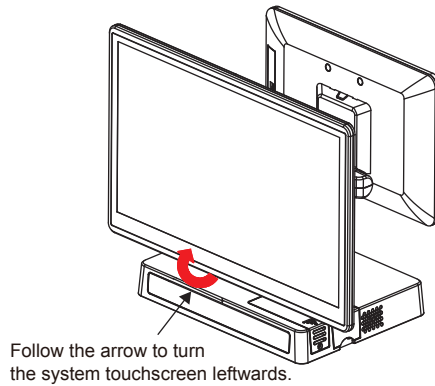

**Note:** Please refer to the “**How To Turn System Touchscreen**” section on the next page on how to turn the primary touchscreen properly.

**Step 2:** Unscrew M.2 2280 and follow the direction of red arrow (as shown) to release the cover.

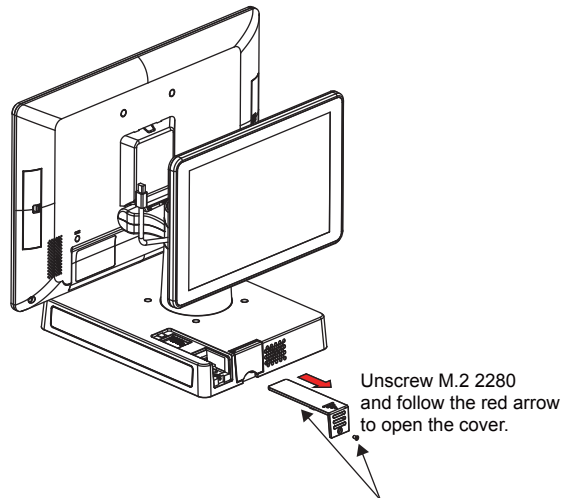

(continued on the next page)

**Step 3:** Slide a new M.2 2280 into the M2. slot and fasten up the screw to secure the cover and complete.

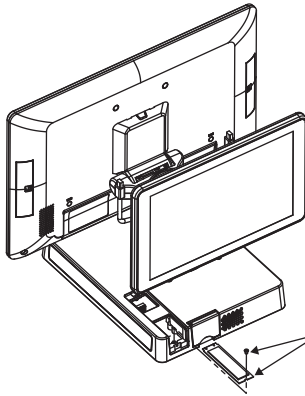

Slide a new M.2 2280 into the M2. slot and fasten up the screw to secure the cover.

## How To Turn System Touchscreen

You can turn the POS touchscreen either way. Heed that after you turn the primary touchscreen to the rear side, you must turn the primary touchscreen only in the direction you previously turned.

PA-J510 System Top View

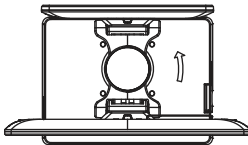

In this example, the primary touchscreen is to be turned leftwards.

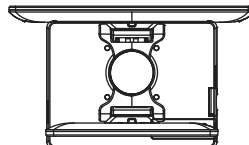

The primary touchscreen has been turned as illustrated.

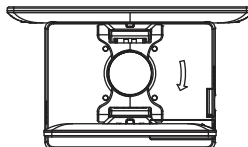

**Important:** Please turn the primary touchscreen only in the direction you previously turned.

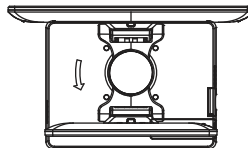

**Warning:** If you force to turn not in the direction you previously turned, the internal structure of the POS system could be damaged.

## 2nd Display Assembly

**Step 1:** Remove Tube Cap.

**Step 2:** Unfasten the 2 screws as shown:

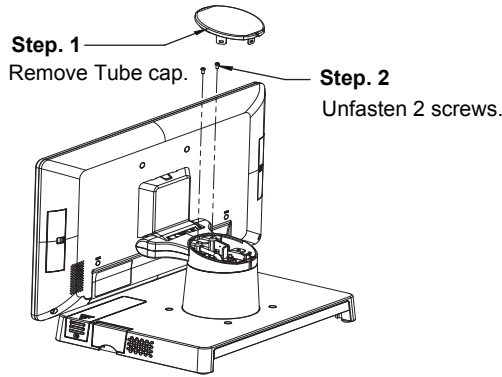

**Step 3:** Fasten 2 HEX CU BOSS (P/N: 22-298-25006301) as shown:

**Step 4:** Install the small LCD support cover onto Tube.

**Step 5:** Fasten the 2 HEX CU BOSS (P/N: 22-298-25018001) to secure the small LCD support cover onto the Tube.

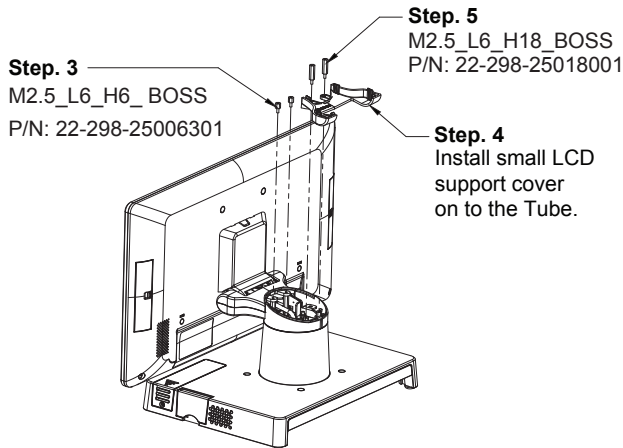

**Step 6:** Fasten the 2 screws (P/N: 22-232-40008211) and install 2nd Display onto the back of PA-J510 Panel PC.

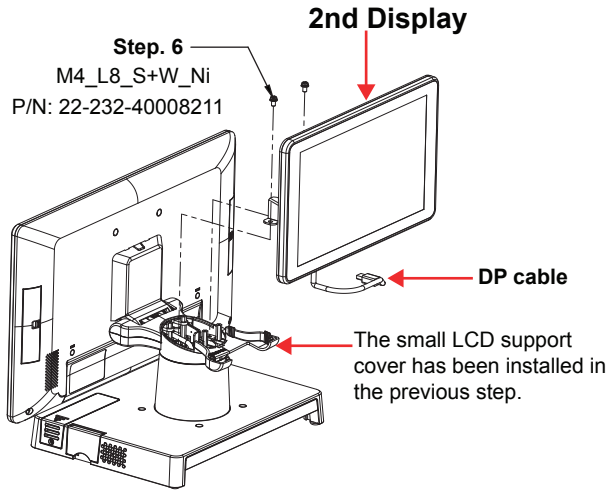

**Step 7:** Wire DP cable into the Tube as shown and out from the top side of rear I/O panel as illustrated below:

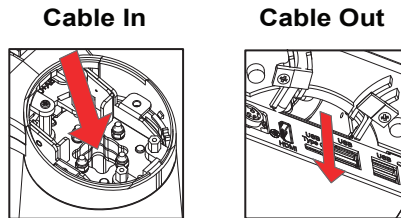

(continued on the next page)

**Step 8:** Plug DP cable into the 2nd Display port on the rear I/O panel as shown:

**Step 9:** Install the screw (P/N: 22-215-30060011) to attach the cable fastener.

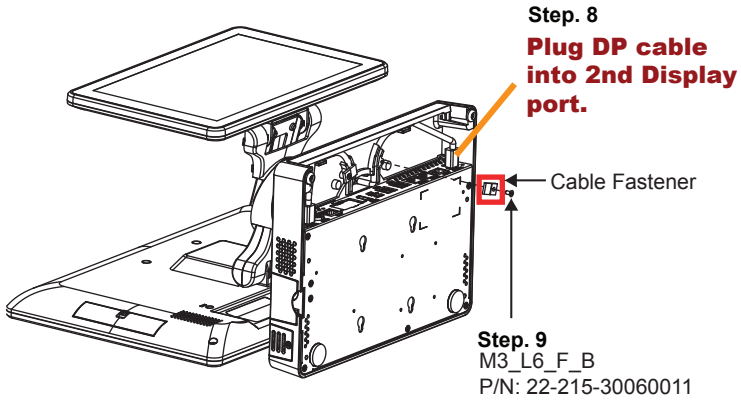

**Step 10:** Install the big LCD small support cover onto the Tube.

**Step 11:** Fasten 4 screws (P/N: 22-232-25006811) to secure big LCD small support cover. Note 2 screws in Step 2 are used in this step.

**Step 12:** Replace Tube Cap to finish the 2nd Display assembly.

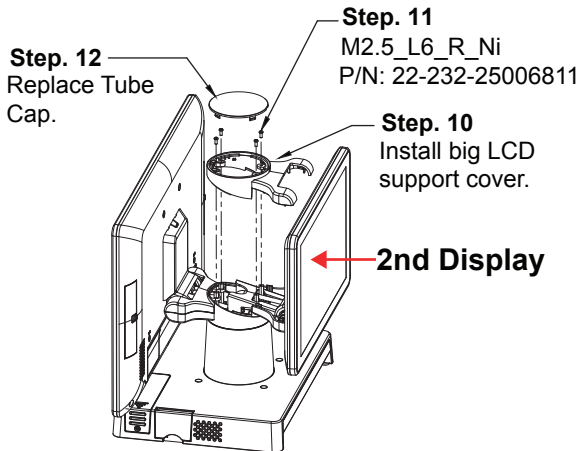



## VFD Module Assembly

**Step 1:** Remove Tube Cap.

**Step 2:** Unfasten the 2 screws as shown:

**Step 3:** Remove the Hinge Cover.

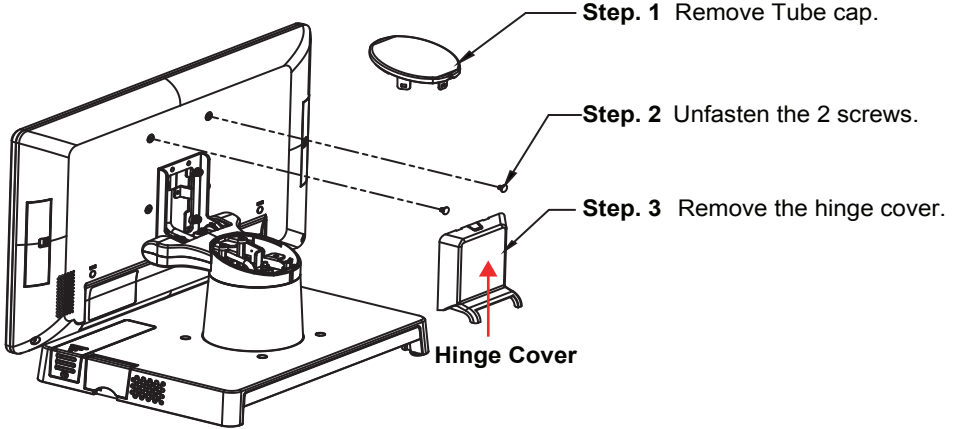

**Step 4:** Tighten 2 screws (P/N: 22-235-40008311) to fix VFD module onto the rear of Panel PC.

**Step 5:** Wire the USB signal cable into the Tube as shown and out from the top side of the rear I/O panel as illustrated below:

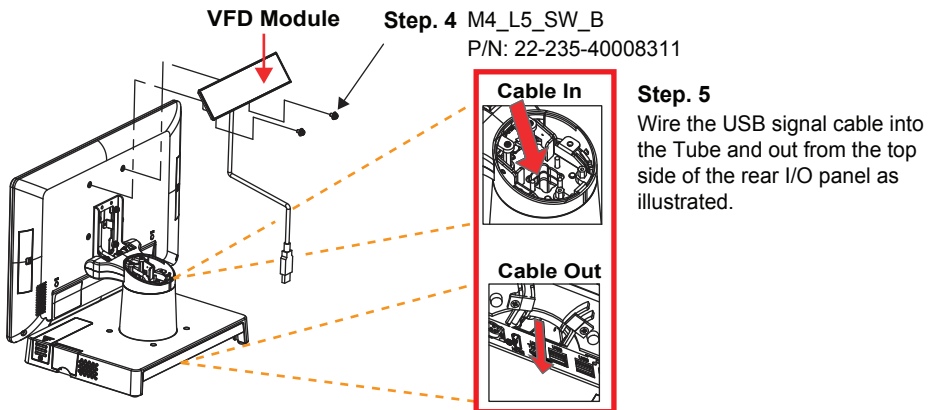

(continued on the next page)

**Step 6:** Plug the USB signal cable into the USB port on the rear I/O panel as shown below:

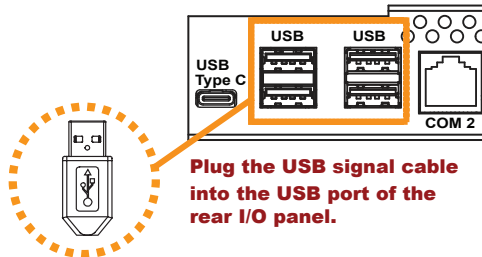

**Step 7:** Cut the pieces of Hinge Cover as shown to allow the cable to wire through.

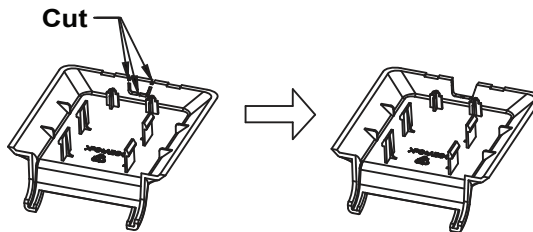

**Step 8:** Replace Tube Cap and Hinge Cover to finish the assembly.

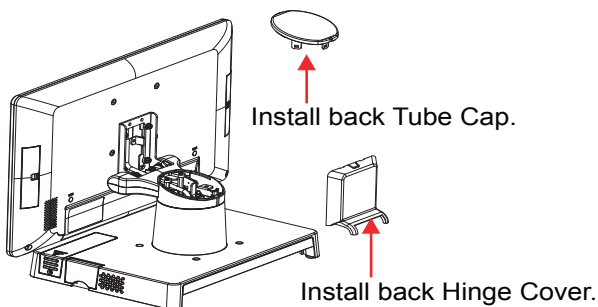

## iButton Module Assembly

**Step 1:** Remove the Cover as shown:

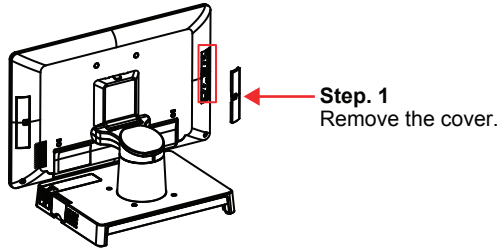

**Step 2:** Connect i-Button cable with the device connector as shown:

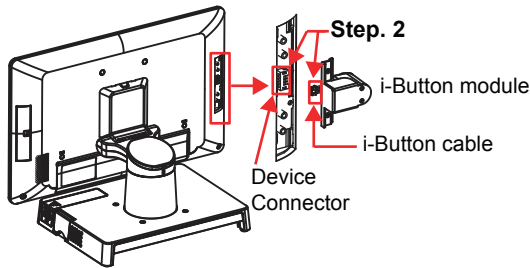

**Step 3:** Fasten 2 screws (P/N: 22-215-30060011) to secure i-Button device onto Panel PC.

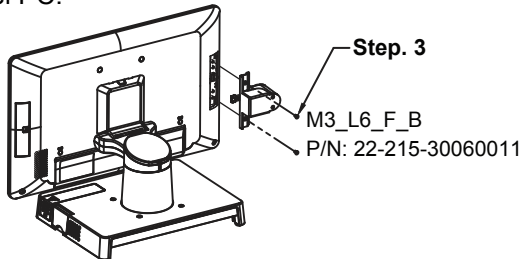

The i-Button module assembly has been finished as below:

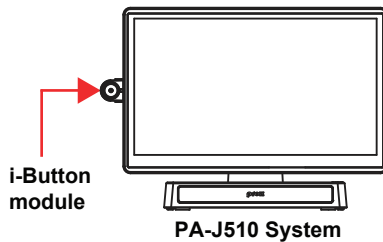

## Fingerprint Module Assembly

**Step 1:** Remove the Cover as shown:

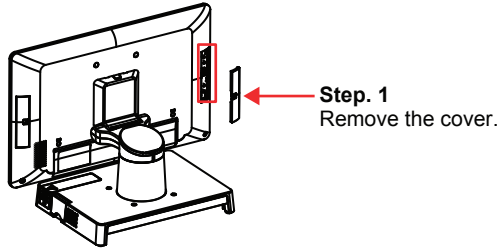

**Step 2:** Connect Fingerprint cable with the device connector as shown:

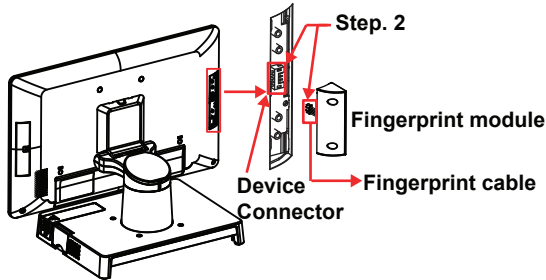

**Step 3:** Tighten 2 screws (P/N: 82-275-30006018) to secure Fingerprint module onto Panel PC.

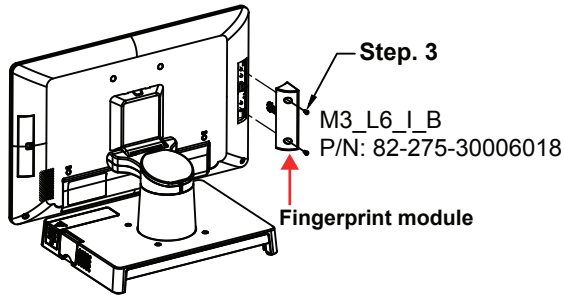

The Fingerprint module assembly has been finished as below:

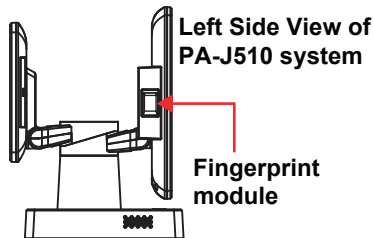

## Barcode Scanner Assembly

**Step 1:** Remove the Cover as shown:

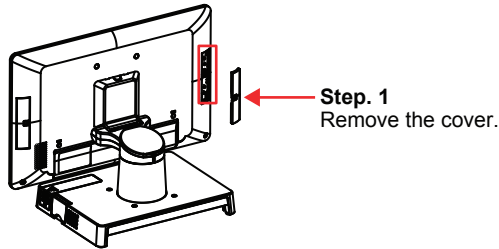

**Step 2:** Connect Barcode Scanner cable with the device connector as shown:

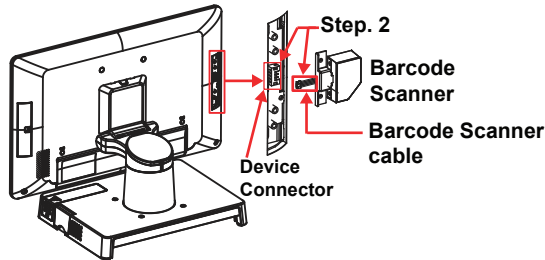

**Step 3:** Fasten 2 screws (P/N: 22-215-30060011) to secure Barcode Scanner onto Panel PC.

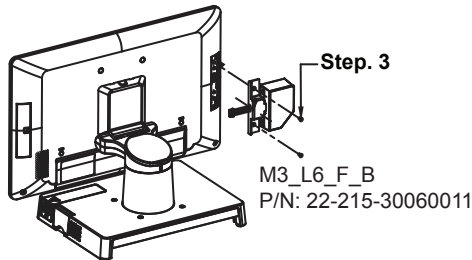

The Barcode Scanner assembly has been finished as below:

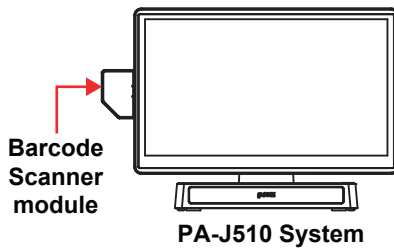

## MSR Module Assembly

**Step 1:** Remove the Cover as shown:

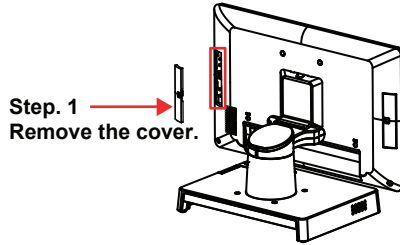

**Step 2:** Connect MSR cable with the device connector as shown:

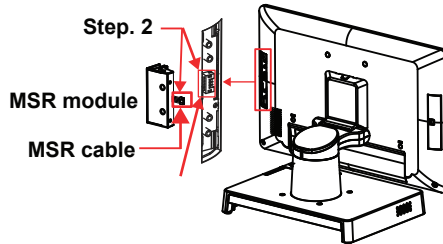

**Step 3:** Tighten 2 screws (P/N: 82-275-30006018) to secure MSR module onto Panel PC.

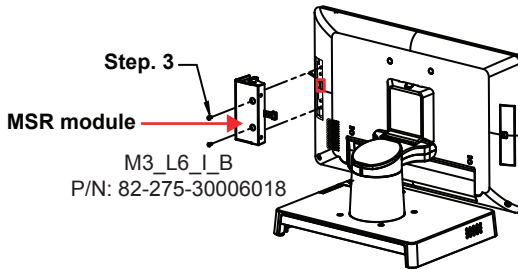

The MSR module assembly has been finished as below:

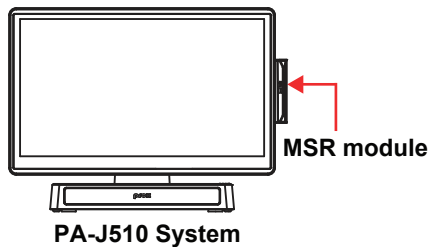

**POS Type Assembly Exploded Diagram**

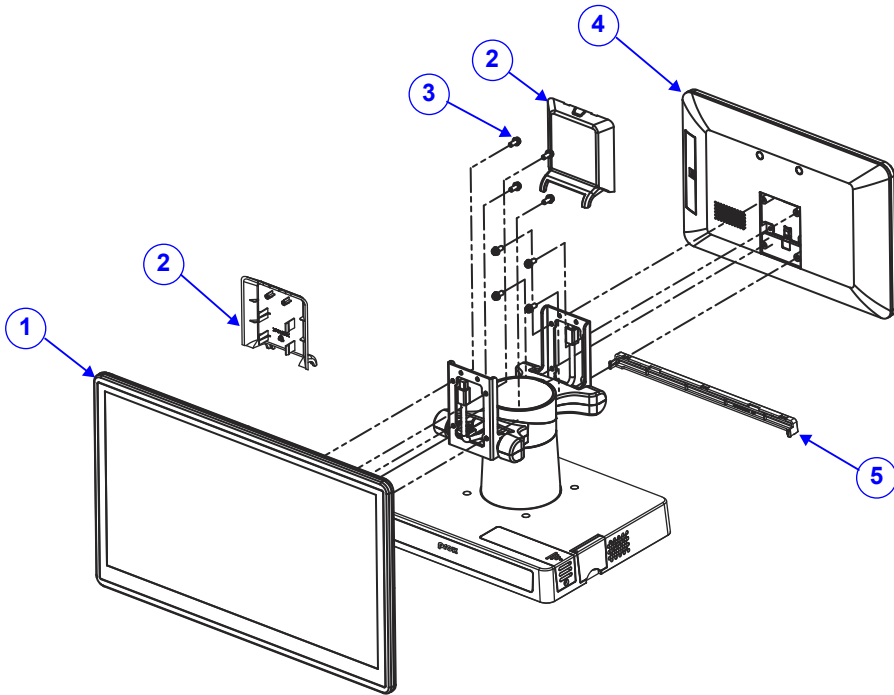

No.	Component Name	P/N No.	Q'ty
1	15" LCD	N/A	1
2	PA-J500 Hinge Cover (Black)	30-002-12210514	2
3	Round Head With Spring Washer Screw #2 / M4x0.7Px10mm	22-232-40010011	13
4	PA-J510 2nd Display	N/A	1
5	PA-J500 Cable Cover (Black)	30-002-12110514	1

**PPC Type Assembly Exploded Diagram**

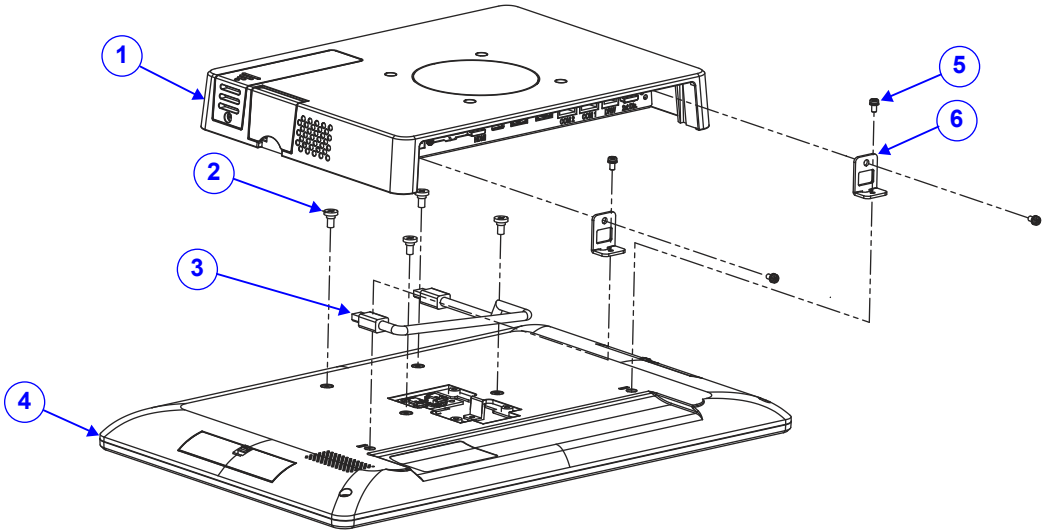

No.	Component Name	P/N No.	Q'ty
1	PA-J510 PPC Box ASM	N/A	1
2	Fillister Head Screw #2 / M4x0.7Px6mm	22-272-40006911	4
3	Mini DP Cable (L=270mm)	27-072-51405111	1
4	15" LCD	N/A	1
5	Round Head With Spring Washer Screw M3x0.5Px6mm	22-232-30060211	4
6	PA-J500 Box Fix	20-040-03002514	2



# Appendix B Technical Summary

---

This appendix will give you a brief introduction of the allocation maps for the system resources.

The following topics are included:

- Block Diagram
- Interrupt Map
- I/O Map
- DMA Channels Map
- Memory Map
- Configuring WatchDog Timer
- Flash BIOS Update

# Block Diagram

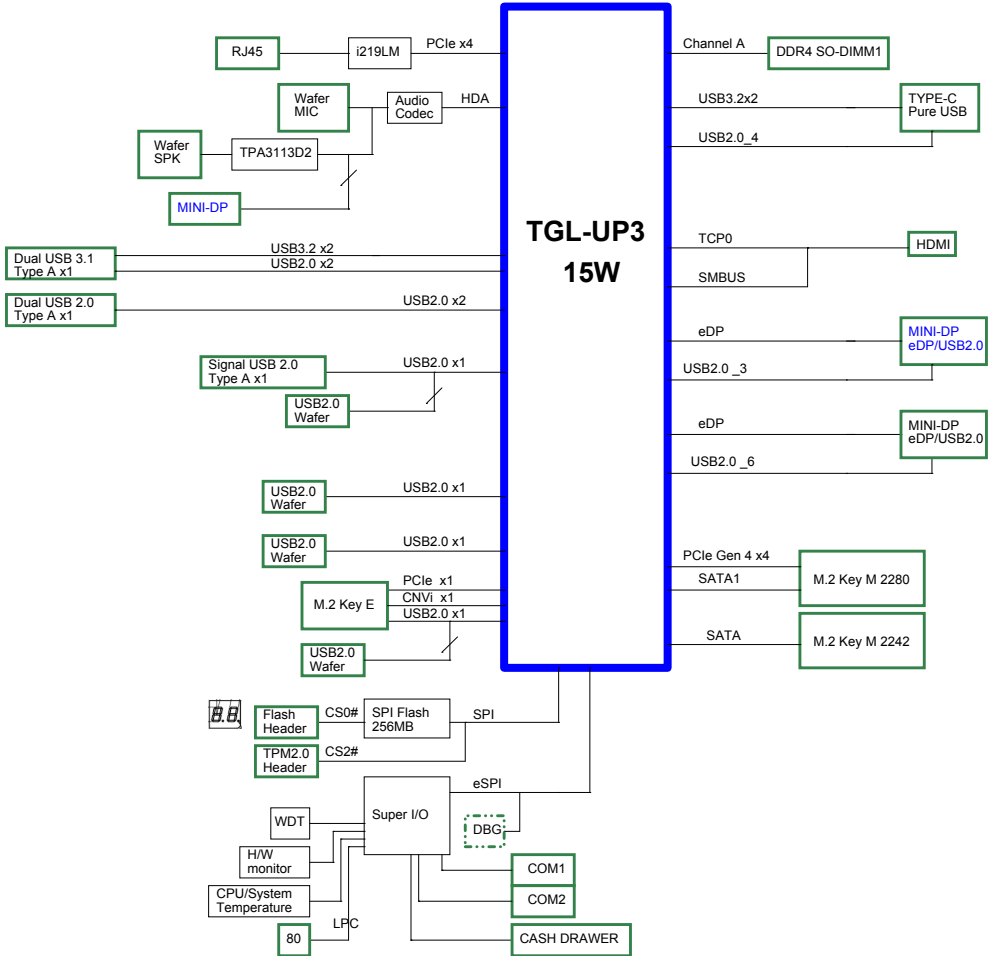

**Interrupt Map**

<b>IRQ</b>	<b>Assignment</b>
IRQ 0	System timer
IRQ 3	Communications Port (COM2)
IRQ 4	Communications Port (COM1)
IRQ 14	Intel(R) Serial IO GPIO Host Controller - INT34C5
IRQ 16	Intel(R) Serial IO UART Host Controller - A0A8
IRQ 16	High Definition Audio Controller
IRQ 17	USB Synopsys Controller
IRQ 18	Intel(R) Serial IO I2C Host Controller - A0D8
IRQ 37	Intel(R) Serial IO SPI Host Controller - A0AB
IRQ 54	Microsoft ACPI-Compliant System
IRQ 55	Microsoft ACPI-Compliant System
IRQ 56	Microsoft ACPI-Compliant System
IRQ 57	Microsoft ACPI-Compliant System
IRQ 58	Microsoft ACPI-Compliant System
IRQ 59	Microsoft ACPI-Compliant System
IRQ 60	Microsoft ACPI-Compliant System
IRQ 61	Microsoft ACPI-Compliant System
IRQ 62	Microsoft ACPI-Compliant System
IRQ 63	Microsoft ACPI-Compliant System
IRQ 64	Microsoft ACPI-Compliant System
IRQ 65	Microsoft ACPI-Compliant System
IRQ 66	Microsoft ACPI-Compliant System
IRQ 67	Microsoft ACPI-Compliant System
IRQ 68	Microsoft ACPI-Compliant System
IRQ 69	Microsoft ACPI-Compliant System
IRQ 70	Microsoft ACPI-Compliant System
IRQ 71	Microsoft ACPI-Compliant System

<b>IRQ</b>	<b>Assignment</b>
IRQ 72	Microsoft ACPI-Compliant System
IRQ 73	Microsoft ACPI-Compliant System
IRQ 74	Microsoft ACPI-Compliant System
IRQ 75	Microsoft ACPI-Compliant System
IRQ 76	Microsoft ACPI-Compliant System
IRQ 77	Microsoft ACPI-Compliant System
IRQ 78	Microsoft ACPI-Compliant System
IRQ 79	Microsoft ACPI-Compliant System
IRQ 80	Microsoft ACPI-Compliant System
IRQ 81	Microsoft ACPI-Compliant System
IRQ 82	Microsoft ACPI-Compliant System
IRQ 83	Microsoft ACPI-Compliant System
IRQ 84	Microsoft ACPI-Compliant System
IRQ 85	Microsoft ACPI-Compliant System
IRQ 86	Microsoft ACPI-Compliant System
IRQ 87	Microsoft ACPI-Compliant System
IRQ 88	Microsoft ACPI-Compliant System
IRQ 89	Microsoft ACPI-Compliant System
IRQ 90	Microsoft ACPI-Compliant System
IRQ 91	Microsoft ACPI-Compliant System
IRQ 92	Microsoft ACPI-Compliant System
IRQ 93	Microsoft ACPI-Compliant System
IRQ 94	Microsoft ACPI-Compliant System
IRQ 95	Microsoft ACPI-Compliant System
IRQ 96	Microsoft ACPI-Compliant System
IRQ 97	Microsoft ACPI-Compliant System
IRQ 98	Microsoft ACPI-Compliant System
IRQ 99	Microsoft ACPI-Compliant System
IRQ 100	Microsoft ACPI-Compliant System

<b>IRQ</b>	<b>Assignment</b>
IRQ 101	Microsoft ACPI-Compliant System
IRQ 102	Microsoft ACPI-Compliant System
IRQ 103	Microsoft ACPI-Compliant System
IRQ 104	Microsoft ACPI-Compliant System
IRQ 105	Microsoft ACPI-Compliant System
IRQ 106	Microsoft ACPI-Compliant System
IRQ 107	Microsoft ACPI-Compliant System
IRQ 108	Microsoft ACPI-Compliant System
IRQ 109	Microsoft ACPI-Compliant System
IRQ 110	Microsoft ACPI-Compliant System
IRQ 111	Microsoft ACPI-Compliant System
IRQ 112	Microsoft ACPI-Compliant System
IRQ 113	Microsoft ACPI-Compliant System
IRQ 114	Microsoft ACPI-Compliant System
IRQ 115	Microsoft ACPI-Compliant System
IRQ 116	Microsoft ACPI-Compliant System
IRQ 117	Microsoft ACPI-Compliant System
IRQ 118	Microsoft ACPI-Compliant System
IRQ 119	Microsoft ACPI-Compliant System
IRQ 120	Microsoft ACPI-Compliant System
IRQ 121	Microsoft ACPI-Compliant System
IRQ 122	Microsoft ACPI-Compliant System
IRQ 123	Microsoft ACPI-Compliant System
IRQ 124	Microsoft ACPI-Compliant System
IRQ 125	Microsoft ACPI-Compliant System
IRQ 126	Microsoft ACPI-Compliant System
IRQ 127	Microsoft ACPI-Compliant System
IRQ 128	Microsoft ACPI-Compliant System
IRQ 129	Microsoft ACPI-Compliant System

<b>IRQ</b>	<b>Assignment</b>
IRQ 130	Microsoft ACPI-Compliant System
IRQ 131	Microsoft ACPI-Compliant System
IRQ 132	Microsoft ACPI-Compliant System
IRQ 133	Microsoft ACPI-Compliant System
IRQ 134	Microsoft ACPI-Compliant System
IRQ 135	Microsoft ACPI-Compliant System
IRQ 136	Microsoft ACPI-Compliant System
IRQ 137	Microsoft ACPI-Compliant System
IRQ 138	Microsoft ACPI-Compliant System
IRQ 139	Microsoft ACPI-Compliant System
IRQ 140	Microsoft ACPI-Compliant System
IRQ 141	Microsoft ACPI-Compliant System
IRQ 142	Microsoft ACPI-Compliant System
IRQ 143	Microsoft ACPI-Compliant System
IRQ 144	Microsoft ACPI-Compliant System
IRQ 145	Microsoft ACPI-Compliant System
IRQ 146	Microsoft ACPI-Compliant System
IRQ 147	Microsoft ACPI-Compliant System
IRQ 148	Microsoft ACPI-Compliant System
IRQ 149	Microsoft ACPI-Compliant System
IRQ 150	Microsoft ACPI-Compliant System
IRQ 151	Microsoft ACPI-Compliant System
IRQ 152	Microsoft ACPI-Compliant System
IRQ 153	Microsoft ACPI-Compliant System
IRQ 154	Microsoft ACPI-Compliant System
IRQ 155	Microsoft ACPI-Compliant System
IRQ 156	Microsoft ACPI-Compliant System
IRQ 157	Microsoft ACPI-Compliant System
IRQ 158	Microsoft ACPI-Compliant System

<b>IRQ</b>	<b>Assignment</b>
IRQ 159	Microsoft ACPI-Compliant System
IRQ 160	Microsoft ACPI-Compliant System
IRQ 161	Microsoft ACPI-Compliant System
IRQ 162	Microsoft ACPI-Compliant System
IRQ 163	Microsoft ACPI-Compliant System
IRQ 164	Microsoft ACPI-Compliant System
IRQ 165	Microsoft ACPI-Compliant System
IRQ 166	Microsoft ACPI-Compliant System
IRQ 167	Microsoft ACPI-Compliant System
IRQ 168	Microsoft ACPI-Compliant System
IRQ 169	Microsoft ACPI-Compliant System
IRQ 170	Microsoft ACPI-Compliant System
IRQ 171	Microsoft ACPI-Compliant System
IRQ 172	Microsoft ACPI-Compliant System
IRQ 173	Microsoft ACPI-Compliant System
IRQ 174	Microsoft ACPI-Compliant System
IRQ 175	Microsoft ACPI-Compliant System
IRQ 176	Microsoft ACPI-Compliant System
IRQ 177	Microsoft ACPI-Compliant System
IRQ 178	Microsoft ACPI-Compliant System
IRQ 179	Microsoft ACPI-Compliant System
IRQ 180	Microsoft ACPI-Compliant System
IRQ 181	Microsoft ACPI-Compliant System
IRQ 182	Microsoft ACPI-Compliant System
IRQ 183	Microsoft ACPI-Compliant System
IRQ 184	Microsoft ACPI-Compliant System
IRQ 185	Microsoft ACPI-Compliant System
IRQ 186	Microsoft ACPI-Compliant System
IRQ 187	Microsoft ACPI-Compliant System

<b>IRQ</b>	<b>Assignment</b>
IRQ 188	Microsoft ACPI-Compliant System
IRQ 189	Microsoft ACPI-Compliant System
IRQ 190	Microsoft ACPI-Compliant System
IRQ 191	Microsoft ACPI-Compliant System
IRQ 192	Microsoft ACPI-Compliant System
IRQ 193	Microsoft ACPI-Compliant System
IRQ 194	Microsoft ACPI-Compliant System
IRQ 195	Microsoft ACPI-Compliant System
IRQ 196	Microsoft ACPI-Compliant System
IRQ 197	Microsoft ACPI-Compliant System
IRQ 198	Microsoft ACPI-Compliant System
IRQ 199	Microsoft ACPI-Compliant System
IRQ 200	Microsoft ACPI-Compliant System
IRQ 201	Microsoft ACPI-Compliant System
IRQ 202	Microsoft ACPI-Compliant System
IRQ 203	Microsoft ACPI-Compliant System
IRQ 204	Microsoft ACPI-Compliant System
IRQ 256	Microsoft ACPI-Compliant System
IRQ 257	Microsoft ACPI-Compliant System
IRQ 258	Microsoft ACPI-Compliant System
IRQ 259	Microsoft ACPI-Compliant System
IRQ 260	Microsoft ACPI-Compliant System
IRQ 261	Microsoft ACPI-Compliant System
IRQ 262	Microsoft ACPI-Compliant System
IRQ 263	Microsoft ACPI-Compliant System
IRQ 264	Microsoft ACPI-Compliant System
IRQ 265	Microsoft ACPI-Compliant System
IRQ 266	Microsoft ACPI-Compliant System
IRQ 267	Microsoft ACPI-Compliant System



<b>IRQ</b>	<b>Assignment</b>
IRQ 268	Microsoft ACPI-Compliant System
IRQ 269	Microsoft ACPI-Compliant System
IRQ 270	Microsoft ACPI-Compliant System
IRQ 271	Microsoft ACPI-Compliant System
IRQ 272	Microsoft ACPI-Compliant System
IRQ 273	Microsoft ACPI-Compliant System
IRQ 274	Microsoft ACPI-Compliant System
IRQ 275	Microsoft ACPI-Compliant System
IRQ 276	Microsoft ACPI-Compliant System
IRQ 277	Microsoft ACPI-Compliant System
IRQ 278	Microsoft ACPI-Compliant System
IRQ 279	Microsoft ACPI-Compliant System
IRQ 280	Microsoft ACPI-Compliant System
IRQ 281	Microsoft ACPI-Compliant System
IRQ 282	Microsoft ACPI-Compliant System
IRQ 283	Microsoft ACPI-Compliant System
IRQ 284	Microsoft ACPI-Compliant System
IRQ 285	Microsoft ACPI-Compliant System
IRQ 286	Microsoft ACPI-Compliant System
IRQ 287	Microsoft ACPI-Compliant System
IRQ 288	Microsoft ACPI-Compliant System
IRQ 289	Microsoft ACPI-Compliant System
IRQ 290	Microsoft ACPI-Compliant System
IRQ 291	Microsoft ACPI-Compliant System
IRQ 292	Microsoft ACPI-Compliant System
IRQ 293	Microsoft ACPI-Compliant System
IRQ 294	Microsoft ACPI-Compliant System
IRQ 295	Microsoft ACPI-Compliant System
IRQ 296	Microsoft ACPI-Compliant System

<b>IRQ</b>	<b>Assignment</b>
IRQ 297	Microsoft ACPI-Compliant System
IRQ 298	Microsoft ACPI-Compliant System
IRQ 299	Microsoft ACPI-Compliant System
IRQ 300	Microsoft ACPI-Compliant System
IRQ 301	Microsoft ACPI-Compliant System
IRQ 302	Microsoft ACPI-Compliant System
IRQ 303	Microsoft ACPI-Compliant System
IRQ 304	Microsoft ACPI-Compliant System
IRQ 305	Microsoft ACPI-Compliant System
IRQ 306	Microsoft ACPI-Compliant System
IRQ 307	Microsoft ACPI-Compliant System
IRQ 308	Microsoft ACPI-Compliant System
IRQ 309	Microsoft ACPI-Compliant System
IRQ 310	Microsoft ACPI-Compliant System
IRQ 311	Microsoft ACPI-Compliant System
IRQ 312	Microsoft ACPI-Compliant System
IRQ 313	Microsoft ACPI-Compliant System
IRQ 314	Microsoft ACPI-Compliant System
IRQ 315	Microsoft ACPI-Compliant System
IRQ 316	Microsoft ACPI-Compliant System
IRQ 317	Microsoft ACPI-Compliant System
IRQ 318	Microsoft ACPI-Compliant System
IRQ 319	Microsoft ACPI-Compliant System
IRQ 320	Microsoft ACPI-Compliant System
IRQ 321	Microsoft ACPI-Compliant System
IRQ 322	Microsoft ACPI-Compliant System
IRQ 323	Microsoft ACPI-Compliant System
IRQ 324	Microsoft ACPI-Compliant System
IRQ 325	Microsoft ACPI-Compliant System

<b>IRQ</b>	<b>Assignment</b>
IRQ 326	Microsoft ACPI-Compliant System
IRQ 327	Microsoft ACPI-Compliant System
IRQ 328	Microsoft ACPI-Compliant System
IRQ 329	Microsoft ACPI-Compliant System
IRQ 330	Microsoft ACPI-Compliant System
IRQ 331	Microsoft ACPI-Compliant System
IRQ 332	Microsoft ACPI-Compliant System
IRQ 333	Microsoft ACPI-Compliant System
IRQ 334	Microsoft ACPI-Compliant System
IRQ 335	Microsoft ACPI-Compliant System
IRQ 336	Microsoft ACPI-Compliant System
IRQ 337	Microsoft ACPI-Compliant System
IRQ 338	Microsoft ACPI-Compliant System
IRQ 339	Microsoft ACPI-Compliant System
IRQ 340	Microsoft ACPI-Compliant System
IRQ 341	Microsoft ACPI-Compliant System
IRQ 342	Microsoft ACPI-Compliant System
IRQ 343	Microsoft ACPI-Compliant System
IRQ 344	Microsoft ACPI-Compliant System
IRQ 345	Microsoft ACPI-Compliant System
IRQ 346	Microsoft ACPI-Compliant System
IRQ 347	Microsoft ACPI-Compliant System
IRQ 348	Microsoft ACPI-Compliant System
IRQ 349	Microsoft ACPI-Compliant System
IRQ 350	Microsoft ACPI-Compliant System
IRQ 351	Microsoft ACPI-Compliant System
IRQ 352	Microsoft ACPI-Compliant System
IRQ 353	Microsoft ACPI-Compliant System
IRQ 354	Microsoft ACPI-Compliant System

<b>IRQ</b>	<b>Assignment</b>
IRQ 355	Microsoft ACPI-Compliant System
IRQ 356	Microsoft ACPI-Compliant System
IRQ 357	Microsoft ACPI-Compliant System
IRQ 358	Microsoft ACPI-Compliant System
IRQ 359	Microsoft ACPI-Compliant System
IRQ 360	Microsoft ACPI-Compliant System
IRQ 361	Microsoft ACPI-Compliant System
IRQ 362	Microsoft ACPI-Compliant System
IRQ 363	Microsoft ACPI-Compliant System
IRQ 364	Microsoft ACPI-Compliant System
IRQ 365	Microsoft ACPI-Compliant System
IRQ 366	Microsoft ACPI-Compliant System
IRQ 367	Microsoft ACPI-Compliant System
IRQ 368	Microsoft ACPI-Compliant System
IRQ 369	Microsoft ACPI-Compliant System
IRQ 370	Microsoft ACPI-Compliant System
IRQ 371	Microsoft ACPI-Compliant System
IRQ 372	Microsoft ACPI-Compliant System
IRQ 373	Microsoft ACPI-Compliant System
IRQ 374	Microsoft ACPI-Compliant System
IRQ 375	Microsoft ACPI-Compliant System
IRQ 376	Microsoft ACPI-Compliant System
IRQ 377	Microsoft ACPI-Compliant System
IRQ 378	Microsoft ACPI-Compliant System
IRQ 379	Microsoft ACPI-Compliant System
IRQ 380	Microsoft ACPI-Compliant System
IRQ 381	Microsoft ACPI-Compliant System
IRQ 382	Microsoft ACPI-Compliant System
IRQ 383	Microsoft ACPI-Compliant System

<b>IRQ</b>	<b>Assignment</b>
IRQ 384	Microsoft ACPI-Compliant System
IRQ 385	Microsoft ACPI-Compliant System
IRQ 386	Microsoft ACPI-Compliant System
IRQ 387	Microsoft ACPI-Compliant System
IRQ 388	Microsoft ACPI-Compliant System
IRQ 389	Microsoft ACPI-Compliant System
IRQ 390	Microsoft ACPI-Compliant System
IRQ 391	Microsoft ACPI-Compliant System
IRQ 392	Microsoft ACPI-Compliant System
IRQ 393	Microsoft ACPI-Compliant System
IRQ 394	Microsoft ACPI-Compliant System
IRQ 395	Microsoft ACPI-Compliant System
IRQ 396	Microsoft ACPI-Compliant System
IRQ 397	Microsoft ACPI-Compliant System
IRQ 398	Microsoft ACPI-Compliant System
IRQ 399	Microsoft ACPI-Compliant System
IRQ 400	Microsoft ACPI-Compliant System
IRQ 401	Microsoft ACPI-Compliant System
IRQ 402	Microsoft ACPI-Compliant System
IRQ 403	Microsoft ACPI-Compliant System
IRQ 404	Microsoft ACPI-Compliant System
IRQ 405	Microsoft ACPI-Compliant System
IRQ 406	Microsoft ACPI-Compliant System
IRQ 407	Microsoft ACPI-Compliant System
IRQ 408	Microsoft ACPI-Compliant System
IRQ 409	Microsoft ACPI-Compliant System
IRQ 410	Microsoft ACPI-Compliant System
IRQ 411	Microsoft ACPI-Compliant System
IRQ 412	Microsoft ACPI-Compliant System

<b>IRQ</b>	<b>Assignment</b>
IRQ 413	Microsoft ACPI-Compliant System
IRQ 414	Microsoft ACPI-Compliant System
IRQ 415	Microsoft ACPI-Compliant System
IRQ 416	Microsoft ACPI-Compliant System
IRQ 417	Microsoft ACPI-Compliant System
IRQ 418	Microsoft ACPI-Compliant System
IRQ 419	Microsoft ACPI-Compliant System
IRQ 420	Microsoft ACPI-Compliant System
IRQ 421	Microsoft ACPI-Compliant System
IRQ 422	Microsoft ACPI-Compliant System
IRQ 423	Microsoft ACPI-Compliant System
IRQ 424	Microsoft ACPI-Compliant System
IRQ 425	Microsoft ACPI-Compliant System
IRQ 426	Microsoft ACPI-Compliant System
IRQ 427	Microsoft ACPI-Compliant System
IRQ 428	Microsoft ACPI-Compliant System
IRQ 429	Microsoft ACPI-Compliant System
IRQ 430	Microsoft ACPI-Compliant System
IRQ 431	Microsoft ACPI-Compliant System
IRQ 432	Microsoft ACPI-Compliant System
IRQ 433	Microsoft ACPI-Compliant System
IRQ 434	Microsoft ACPI-Compliant System
IRQ 435	Microsoft ACPI-Compliant System
IRQ 436	Microsoft ACPI-Compliant System
IRQ 437	Microsoft ACPI-Compliant System
IRQ 438	Microsoft ACPI-Compliant System
IRQ 439	Microsoft ACPI-Compliant System
IRQ 440	Microsoft ACPI-Compliant System
IRQ 441	Microsoft ACPI-Compliant System

<b>IRQ</b>	<b>Assignment</b>
IRQ 442	Microsoft ACPI-Compliant System
IRQ 443	Microsoft ACPI-Compliant System
IRQ 444	Microsoft ACPI-Compliant System
IRQ 445	Microsoft ACPI-Compliant System
IRQ 446	Microsoft ACPI-Compliant System
IRQ 447	Microsoft ACPI-Compliant System
IRQ 448	Microsoft ACPI-Compliant System
IRQ 449	Microsoft ACPI-Compliant System
IRQ 450	Microsoft ACPI-Compliant System
IRQ 451	Microsoft ACPI-Compliant System
IRQ 452	Microsoft ACPI-Compliant System
IRQ 453	Microsoft ACPI-Compliant System
IRQ 454	Microsoft ACPI-Compliant System
IRQ 455	Microsoft ACPI-Compliant System
IRQ 456	Microsoft ACPI-Compliant System
IRQ 457	Microsoft ACPI-Compliant System
IRQ 458	Microsoft ACPI-Compliant System
IRQ 459	Microsoft ACPI-Compliant System
IRQ 460	Microsoft ACPI-Compliant System
IRQ 461	Microsoft ACPI-Compliant System
IRQ 462	Microsoft ACPI-Compliant System
IRQ 463	Microsoft ACPI-Compliant System
IRQ 464	Microsoft ACPI-Compliant System
IRQ 465	Microsoft ACPI-Compliant System
IRQ 466	Microsoft ACPI-Compliant System
IRQ 467	Microsoft ACPI-Compliant System
IRQ 468	Microsoft ACPI-Compliant System
IRQ 469	Microsoft ACPI-Compliant System
IRQ 470	Microsoft ACPI-Compliant System

<b>IRQ</b>	<b>Assignment</b>
IRQ 471	Microsoft ACPI-Compliant System
IRQ 472	Microsoft ACPI-Compliant System
IRQ 473	Microsoft ACPI-Compliant System
IRQ 474	Microsoft ACPI-Compliant System
IRQ 475	Microsoft ACPI-Compliant System
IRQ 476	Microsoft ACPI-Compliant System
IRQ 477	Microsoft ACPI-Compliant System
IRQ 478	Microsoft ACPI-Compliant System
IRQ 479	Microsoft ACPI-Compliant System
IRQ 480	Microsoft ACPI-Compliant System
IRQ 481	Microsoft ACPI-Compliant System
IRQ 482	Microsoft ACPI-Compliant System
IRQ 483	Microsoft ACPI-Compliant System
IRQ 484	Microsoft ACPI-Compliant System
IRQ 485	Microsoft ACPI-Compliant System
IRQ 486	Microsoft ACPI-Compliant System
IRQ 487	Microsoft ACPI-Compliant System
IRQ 488	Microsoft ACPI-Compliant System
IRQ 489	Microsoft ACPI-Compliant System
IRQ 490	Microsoft ACPI-Compliant System
IRQ 491	Microsoft ACPI-Compliant System
IRQ 492	Microsoft ACPI-Compliant System
IRQ 493	Microsoft ACPI-Compliant System
IRQ 494	Microsoft ACPI-Compliant System
IRQ 495	Microsoft ACPI-Compliant System
IRQ 496	Microsoft ACPI-Compliant System
IRQ 497	Microsoft ACPI-Compliant System
IRQ 498	Microsoft ACPI-Compliant System
IRQ 499	Microsoft ACPI-Compliant System



IRQ	Assignment
IRQ 500	Microsoft ACPI-Compliant System
IRQ 501	Microsoft ACPI-Compliant System
IRQ 502	Microsoft ACPI-Compliant System
IRQ 503	Microsoft ACPI-Compliant System
IRQ 504	Microsoft ACPI-Compliant System
IRQ 505	Microsoft ACPI-Compliant System
IRQ 506	Microsoft ACPI-Compliant System
IRQ 507	Microsoft ACPI-Compliant System
IRQ 508	Microsoft ACPI-Compliant System
IRQ 509	Microsoft ACPI-Compliant System
IRQ 510	Microsoft ACPI-Compliant System
IRQ 511	Microsoft ACPI-Compliant System
IRQ 4294967283	Intel(R) Management Engine Interface #1
IRQ 4294967284	Intel(R) Ethernet Connection (13) I219-V
IRQ 4294967285	Intel(R) USB 3.10 eXtensible Host Controller - 1.20 (Microsoft)
IRQ 4294967286	Intel(R) USB 3.10 eXtensible Host Controller - 1.20 (Microsoft)
IRQ 4294967287	Intel(R) UHD Graphics
IRQ 4294967288	Standard SATA AHCI Controller
IRQ 4294967289	Standard NVM Express Controller
IRQ 4294967290	Standard NVM Express Controller
IRQ 4294967291	Standard NVM Express Controller
IRQ 4294967292	Standard NVM Express Controller
IRQ 4294967293	Standard NVM Express Controller
IRQ 4294967294	Intel(R) PEG60 - 9A09

**Note:** These resource information were gathered using Windows 10.  
 (The IRQ could be assigned differently depending on OS)

**I/O MAP**

<b>I/O Map</b>	<b>Assignment</b>
0x00000000-0x00000CF7	PCI Express Root Complex
0x00000020-0x00000021	Programmable interrupt controller
0x00000024-0x00000025	Programmable interrupt controller
0x00000028-0x00000029	Programmable interrupt controller
0x0000002C-0x0000002D	Programmable interrupt controller
0x0000002E-0x0000002F	Motherboard resources
0x00000030-0x00000031	Programmable interrupt controller
0x00000034-0x00000035	Programmable interrupt controller
0x00000038-0x00000039	Programmable interrupt controller
0x0000003C-0x0000003D	Programmable interrupt controller
0x00000040-0x00000043	System timer
0x0000004E-0x0000004F	Motherboard resources
0x00000050-0x00000053	System timer
0x00000061-0x00000061	Motherboard resources
0x00000063-0x00000063	Motherboard resources
0x00000065-0x00000065	Motherboard resources
0x00000067-0x00000067	Motherboard resources
0x00000070-0x00000070	Motherboard resources
0x00000080-0x00000080	Motherboard resources
0x00000092-0x00000092	Motherboard resources
0x000000A0-0x000000A1	Programmable interrupt controller
0x000000A4-0x000000A5	Programmable interrupt controller
0x000000A8-0x000000A9	Programmable interrupt controller
0x000000AC-0x000000AD	Programmable interrupt controller

<b>I/O Map</b>	<b>Assignment</b>
0x000000B0-0x000000B1	Programmable interrupt controller
0x000000B2-0x000000B3	Motherboard resources
0x000000B4-0x000000B5	Programmable interrupt controller
0x000000B8-0x000000B9	Programmable interrupt controller
0x000000BC-0x000000BD	Programmable interrupt controller
0x000002F8-0x000002FF	Communications Port (COM2)
0x000003F8-0x000003FF	Communications Port (COM1)
0x000004D0-0x000004D1	Programmable interrupt controller
0x00000680-0x0000069F	Motherboard resources
0x00000A00-0x00000A0F	Motherboard resources
0x00000A10-0x00000A1F	Motherboard resources
0x00000A20-0x00000A2F	Motherboard resources
0x00000D00-0x0000FFFF	PCI Express Root Complex
0x0000164E-0x0000164F	Motherboard resources
0x00001800-0x000018FE	Motherboard resources
0x00001854-0x00001857	Motherboard resources
0x00002000-0x000020FE	Motherboard resources
0x00003000-0x0000303F	Intel(R) UHD Graphics
0x00003060-0x0000307F	Standard SATA AHCI Controller
0x00003080-0x00003083	Standard SATA AHCI Controller
0x00003090-0x00003097	Standard SATA AHCI Controller
0x0000EFA0-0x0000EFBF	Intel(R) SMBus - A0A3

## Memory Map

Memory Map	Assignment
0xFEDC0000-0xFEDC7FFF	Motherboard resources
0xFEDA0000-0xFEDA0FFF	Motherboard resources
0xFEDA1000-0xFEDA1FFF	Motherboard resources
0xC0000000-0xCFFFFFFF	Motherboard resources
0xFED20000-0xFED7FFFF	Motherboard resources
0xFED90000-0xFED93FFF	Motherboard resources
0xFED45000-0xFED8FFFF	Motherboard resources
0xFEE00000-0xFEEFFFFFFF	Motherboard resources
0xBF000000-0xBF000000	Intel(R) Ethernet Connection (13) I219-V
0xFFCFCB000-0xFFCFCBFFF	Intel(R) Serial IO UART Host Controller - A0A8
0x1310000-0x131FFFFF	Intel(R) USB 3.10 eXtensible Host Controller - 1.20 (Microsoft)
0xFED00000-0xFED003FF	High precision event timer
0x1300000-0x130FFFFF	Intel(R) USB 3.10 eXtensible Host Controller - 1.20 (Microsoft)
0xFFCFA000-0xFFCFAFFF	Intel(R) Serial IO I2C Host Controller - A0D8
0xFE000000-0xFE01FFFF	Motherboard resources
0xFE04C000-0xFE04FFFF	Motherboard resources
0xFE050000-0xFE0AFFFF	Motherboard resources
0xFE0D0000-0xFE0FFFFFFF	Motherboard resources
0xFE200000-0xFE7FFFFFFF	Motherboard resources
0xFF000000-0xFFFFFFFF	Motherboard resources
0xFD000000-0xFD68FFFF	Motherboard resources
0xFD6B0000-0xFD6CFFFF	Motherboard resources
0xFD6F0000-0xFDFFFFFFF	Motherboard resources

Memory Map	Assignment
0x1329000-0x1329FFF	Intel(R) Serial IO SPI Host Controller - A0AB
0x0000-0xFFFFFFFF	Intel(R) UHD Graphics
0x0000-0xFFFFFFFF	Intel(R) UHD Graphics
0xFE010000-0xFE010FFF	Intel(R) SPI (flash) Controller - A0A4
0xFD6E0000-0xFD6EFFFF	Intel(R) Serial IO GPIO Host Controller - INT34C5
0xFD6D0000-0xFD6DFFFF	Intel(R) Serial IO GPIO Host Controller - INT34C5
0xFD6A0000-0xFD6AFFFF	Intel(R) Serial IO GPIO Host Controller - INT34C5
0xFD690000-0xFD69FFFF	Intel(R) Serial IO GPIO Host Controller - INT34C5
0xFED40000-0xFED44FFF	Trusted Platform Module 2.0
0xFFCF9000-0xFFCF9FFF	Intel(R) Management Engine Interface #1
0xFFCFC000-0xFFCFFFFF	High Definition Audio Controller
0xFFD00000-0xFFDFFFFF	High Definition Audio Controller
0xFFE00000-0xFFFFFFFF	USB Synopsys Controller
0xFFCF8000-0xFFCF8FFF	USB Synopsys Controller
0x1328000-0x13280FFF	Intel(R) SMBus - A0A3
0xA0000-0xBFFFF	PCI Express Root Complex
0xE0000-0xE3FFF	PCI Express Root Complex
0xE4000-0xE7FFF	PCI Express Root Complex
0xE8000-0xEBFFF	PCI Express Root Complex
0xEC000-0xEFFFF	PCI Express Root Complex
0xF0000-0xFFFFF	PCI Express Root Complex
0x50400000-0x50403FFF	Standard NVM Express Controller
0x50400000-0x50403FFF	PCI Express Root Complex

<b>Memory Map</b>	<b>Assignment</b>
0x50400000-0x50403FFF	Intel(R) PEG60 - 9A09
0x50520000-0x50521FFF	Standard SATA AHCI Controller
0x50522000-0x505227FF	Standard SATA AHCI Controller
0x50523000-0x505230FF	Standard SATA AHCI Controller

## **B-Configuring WatchDog Timer**

The I/O port address of the watchdog timer is 2E (hex) and 2F (hex). 2E (hex) is the address port. 2F (hex) is the data port. User must first assign the address of register by writing address value into address port 2E (hex), then write/read data to/from the assigned register through data port 2F (hex).

### **Configuration Sequence**

To program F81967 configuration registers, the following configuration sequence must be followed:

#### **(1) Enter the extended function mode**

To place the chip into the Extended Function Mode, two successive writes of 0x87 must be applied to Extended Function Enable Registers (EFERs, i.e. 2Eh or 4Eh).

#### **(2) Configure the configuration registers**

The chip selects the Logical Device and activates the desired Logical Devices through Extended Function Index Register (EFIR) and Extended Function Data Register (EFDR). The EFIR is located at the same address as the EFER, and the EFDR is located at address (EFIR+1). First, write the Logical Device Number (i.e. 0x07) to the EFIR and then write the number of the desired Logical Device to the EFDR. If accessing the Chip (Global) Control Registers, this step is not required. Secondly, write the address of the desired configuration register within the Logical Device to the EFIR and then write (or read) the desired configuration register through the EFDR.

#### **(3) Exit the extended function mode**

To exit the Extended Function Mode, writing 0xAA to the EFER is required. Once the chip exits the Extended Function Mode, it is in the normal running mode and is ready to enter the configuration mode.

**Code example for watch dog timer**

Enable watchdog timer and set timeout interval to 30 seconds.

```

;----- Enter to extended function mode -----
mov  dx,  2Eh
mov  al,  87h
out  dx,  al
out  dx,  al
;----- Select Logical Device 7 of watchdog timer -----
mov  al,  07h
out  dx,  al
inc  dx
mov  al,  07h
out  dx,  al
;----- Enable Watch dog feature -----
dec  dx
mov  al,  30h
out  dx,  al
inc  dx
mov  al,  01h
out  dx,  al
;----- Set timeout interval as 30seconds and start counting -----
dec  dx
mov  al,  F6h
out  dx,  al
inc  dx
mov  al,  1Eh
out  dx,  al
;----- Enable Watch PME-----
dec  dx
mov  al,  FAh
out  dx,  al
inc  dx
in   al,  dx
or   al,  51h
out  dx,  al
;----- Set second as counting unit -----
dec  dx
mov  al,  F5h
out  dx,  al
inc  dx
in   al,  dx
and  al,  DEh
out  dx,  al
;----- Start the watchdog timer -----
or   al,  20h
out  dx,  al
;----- Exit the extended function mode -----
dec  dx
mov  al,  AAh
out  dx,  al

```



## Flash BIOS Update

### I. Prerequisites

- 1 Prepare a bootable media (e.g. USB storage device) which can boot system to EFI Shell. Note: Copy UEFI Shell into the storage device under specific directory path. (/efi/boot/bootx64.efi)
- 2 Download and save the BIOS file (e.g. J5000PU1) to the storage device.
- 3 Copy AMI flash utility – AfuEfix64.efi (v5.14.01.0015) into the storage device. The utility and BIOS file should be saved to the same path.
- 4 Make sure the target system can first boot to the bootable device.
  - (1) Connect the bootable USB device.
  - (2) Turn on the computer and press <ESC> or <DEL> key during boot to enter BIOS Setup.
  - (3) Select [**Boot**] menu and set the USB bootable device to be the 1<sup>st</sup> boot device.
  - (4) Press <F4> to save the configuration and exit the BIOS setup menu.

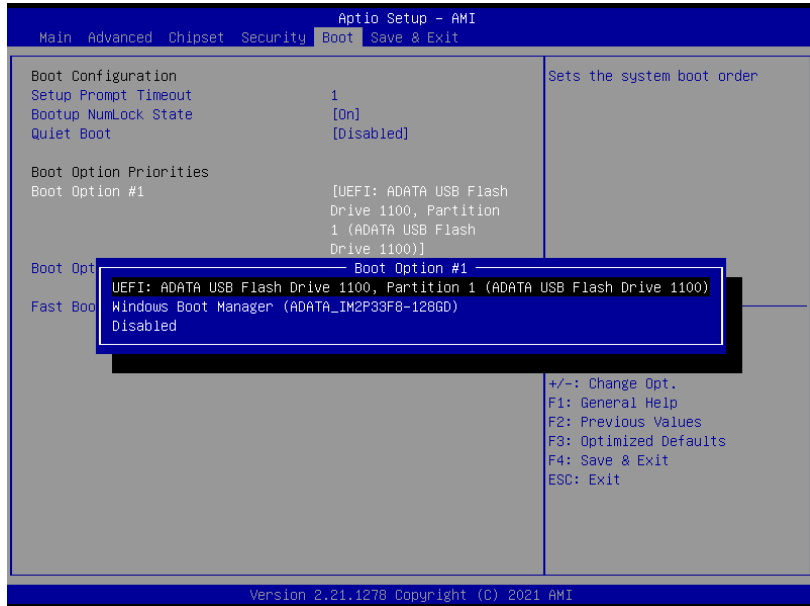

## **II. AFUEFIx64 Command for System BIOS Update**

AFUEFIx64.efi is the AMI firmware update utility; the command line is shown as below:

**AFUEFIx64 <ROM File Name> [option1] [option2]....**

Users can type “**AFUEFIx64 /?**” to view the definition of each control option. The recommended options for BIOS ROM update include the following parameters:

- /P:** Program main BIOS image.
- /B:** Program Boot Block.
- /N:** Program NVRAM.
- /X:** Don't check ROM ID.

### III. BIOS Update Procedure

- 1 Use the bootable USB storage to boot up system into the EFI Shell.
- 2 Type "**AfuEfix64 J500xxxx.bin /p /b /n /x**" and press enter to start the flash procedure. (xxxx means the BIOS revision part, e.g. 0PM1...)
- 3 During the update procedure, you will see the BIOS update process status and its execution percentage. Beware! Do not turn off the system power or reset your computer if the whole procedure are not complete yet, or it may crash the BIOS ROM and the system will be unable to boot up next time.
- 4 After the BIOS update procedure is completed, the following messages will be shown:

```
Shell> fs0:
fs0:\afuefix64> AFUEFIX64 J5000PU1.bin /p /b /n /x
+-----+
|          AMI Firmware Update Utility v5.14.01.0015          |
| Copyright (C) 1985-2019, American Megatrends International LLC. |
| All Rights Reserved. Subject to AMI licensing agreement.     |
+-----+
Reading flash ..... done
- ME Data Size Checking. ok
- FFS checksums ..... ok
- Check RomLayout ..... ok
Erasing Boot Block ..... done
Updating Boot Block ..... done
Verifying Boot Block ..... done
Erasing Main Block ..... done
Updating Main Block ..... done
Verifying Main Block ..... done
Erasing NVRAM Block ..... done
Updating NVRAM Block ..... done
Verifying NVRAM Block ..... done
fs0:\afuefix64>
```

- 5 Restart the system and boot up with the new BIOS configurations.
- 6 The BIOS Update is completed after the system is restarted.

- 7 Reboot the system and verify if the BIOS version shown on the initialization screen has been updated.

