

# MP-4815

## Quick Reference Guide

Designed for PA-6225

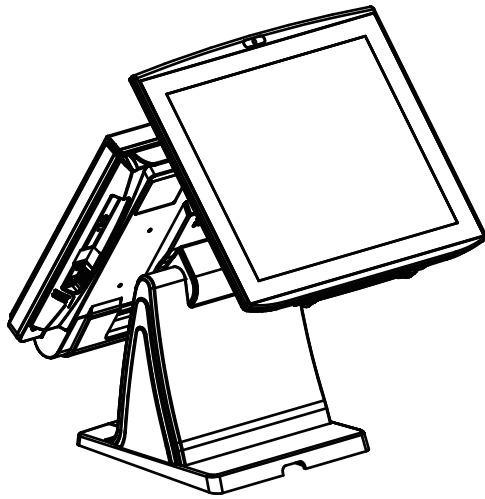

Ver. Q1

All Rights Reserved. Copyright 2017

## Packing Checklist

If you discover any item below are damaged or lost, please contact your vendor immediately.

- MP-4815 x1
- This Quick Reference Guide x1
- Manual DVD x1
- MP-4815 EPE Right x1
- MP-4815 EPE Left x1

## MP-4815

### Specifications

#### 2nd Display

|                     |   |
|---------------------|---|
| Display             | 15-inch LCD panel   |
| Resolution          | LVDS 1024x768 dots XGA (24-bit)   |
| Brightness          | Typ. 300 cd/ m <sup>2</sup>   |
| Backlight Lamp      | Life time: min. 50,000 hours  |
| Touch Panel         | P-CAP touch (Bezel free) or Resistive Touch   |
| Touch Control Board | Only for 15-inch Resistive Touch Panel (USB Interface)  |
| Speaker             | 3W+3W@4 ohm speaker   |
| Power Supply        | DC12V/3.33A/ 40W Power Adapter, 90 ~240 Vac, 50/60Hz  |
| Wall Mount          | VESA Mount 100x100 mm   |
| Dimension (WxHxD)   | 367 x 300 x 38 mm   |
| Weight              | <ul style="list-style-type: none"> <li>• MP-4815: 3.1 kg</li> <li>• MP-4815 2nd Display + PA-6225: 12.6 kg</li> </ul> |
| Certificate         | CE  |

#### Rear I/O Ports

|       |                                       |
|-------|---------------------------------------|
| DC IN | 1 x DC-IN port                        |
| USB   | 1 x USB 2.0 port, Type B (downstream) |
| VGA   | 1 x VGA port                          |

#### Optional Integrated Module

|                 |  |
|-----------------|--|
| Module Mounting | Provides mounting holes on right side to fix other devices |
|-----------------|--|

#### Optional Integrated Devices

|        |                               |
|--------|-------------------------------|
| Camera | Camera module (USB Interface) |
|--------|-------------------------------|

#### Environment

|                 |                             |
|-----------------|-----------------------------|
| Operating Temp. | 0°C ~ 40°C (32°F ~ 104°F)   |
| Storage Temp.   | -20°C ~ 60°C (-4°F ~ 140°F) |
| Humidity        | 10% ~ 90%                   |

## MP-4815

### System View

Unit: mm

#### Front View

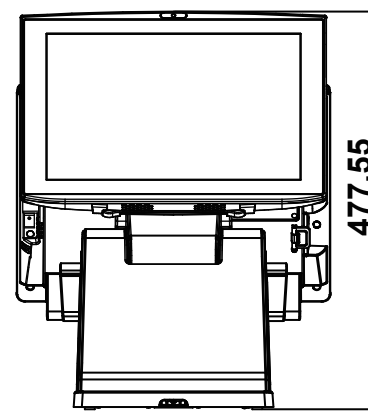

#### Side View

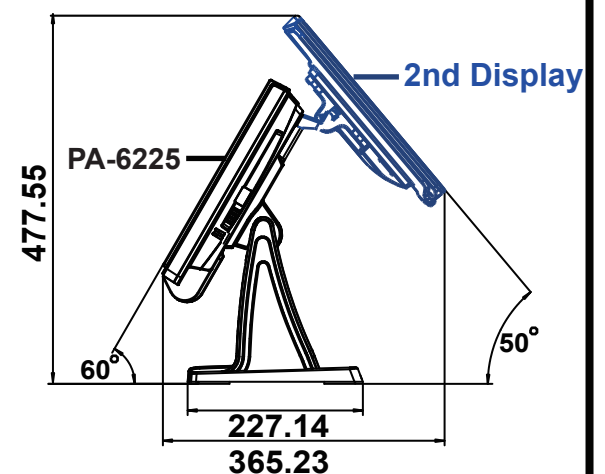

#### REAR I/O

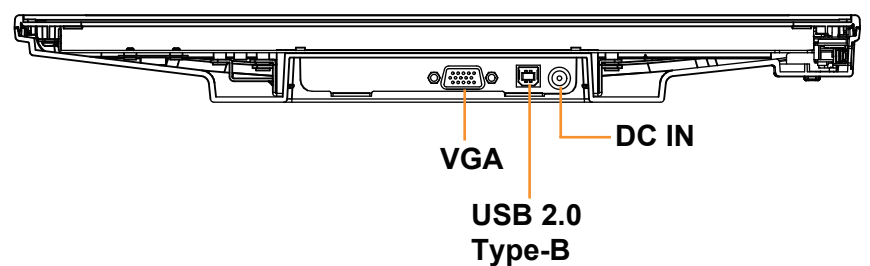

#### Quarter View

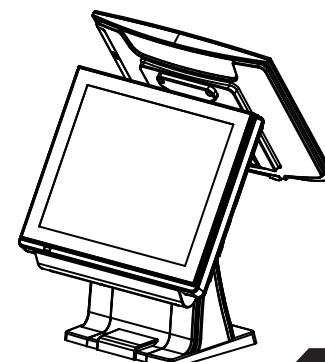

# MP-4815

## 15" 2nd Display

### Jumper Setting

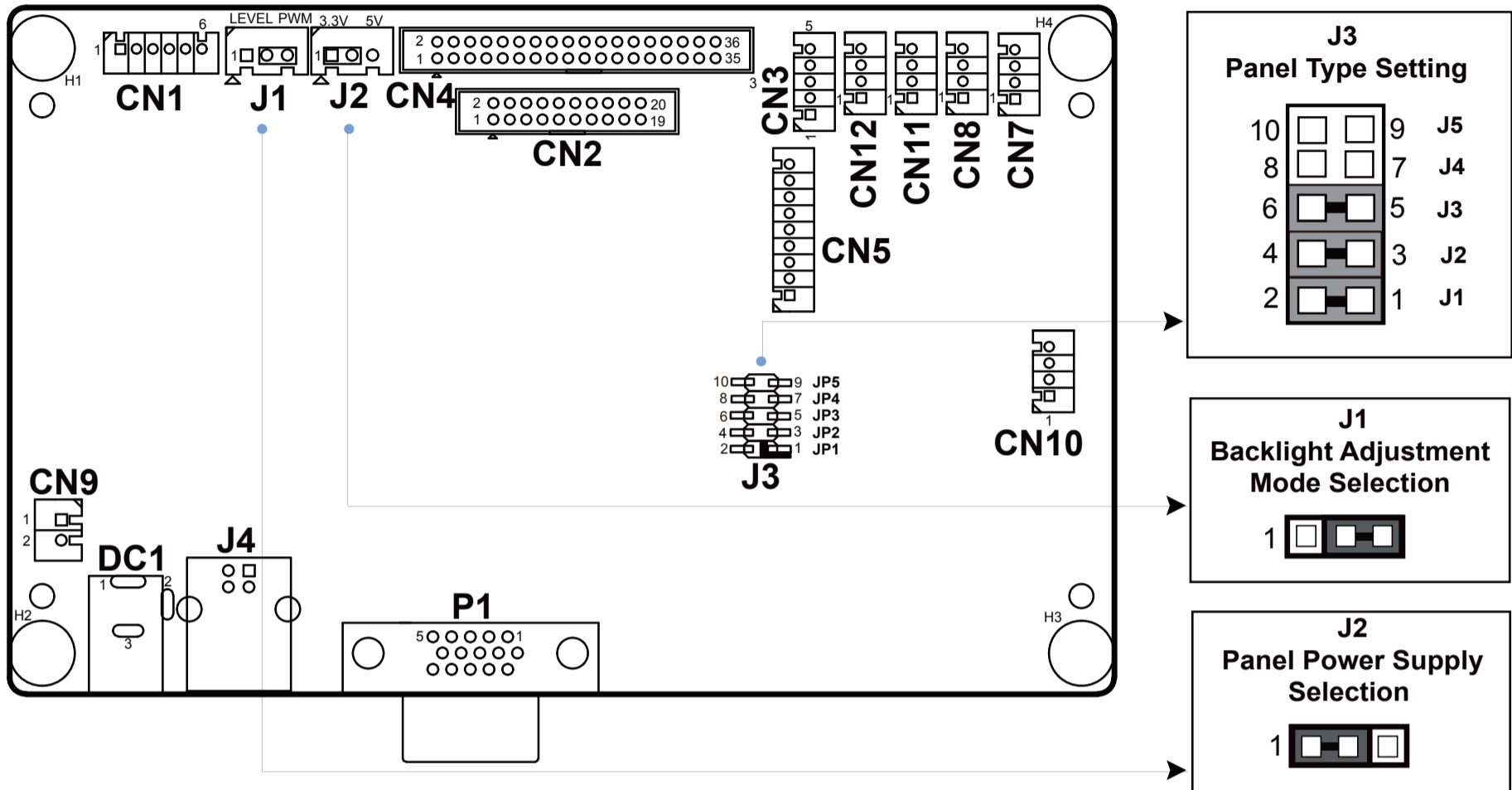

**CAUTION!** Danger of explosion may occur if the battery is replaced incorrectly. Replace batteries only with the same or equivalent type recommended by the manufacturer. Dispose the used batteries according to the manufacturer's instructions.

### Safety Precaution

The following messages are safety reminders on how to protect your system from damages, and thus extend the life cycle of the system.

1. Check the Line Voltage
  - The operating voltage for the power supply should cover the range of 9V~36V DC; otherwise, the system may be damaged.
2. Environmental Conditions
  - Place your MP-4815 on a sturdy, level surface. Be sure to allow enough room on each side to have easy access.
  - Avoid moving the system rapidly from a hot place to a cold place or vice versa because condensation may come from inside of the system.
  - Place MP-4815 against strong vibrations, which may cause hard disk failure.
3. Handling
  - Do not turn the system upside down. This may cause the hard drive to malfunction.

- Do not allow foreign objects to fall into this product.
  - If water or other liquid spills into this product, unplug the power cord immediately.
4. Good Care
    - When the outside of the case is stained, remove the stain with neutral washing agent with a dry cloth.
    - If dust has been accumulated on the outside, remove it by using a vacuum cleaner specially made for computers.

**CAUTION!**

Danger of explosion if battery is incorrectly replaced. Replace only with the same or equivalent type recommended by the manufacturer. Dispose of used batteries according to the manufacturer's instructions.

**WARNING!**

Some internal parts of the system may have high electrical voltage. Therefore we strongly recommend qualified engineers open and disassemble the system.

**Packing Checklist**

**MP-4815**

**Quick Reference Guide**

Designed for PA-6322

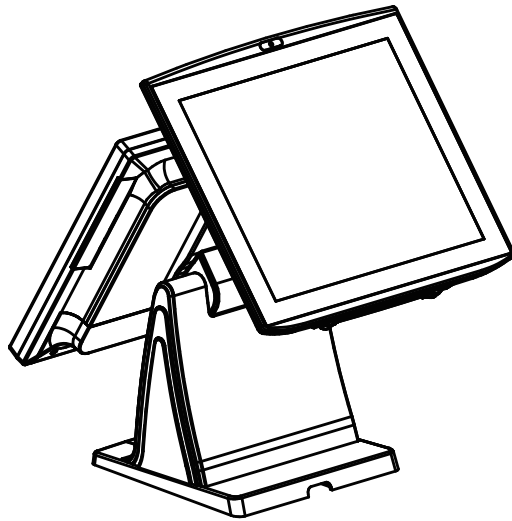

Ver. Q1

All Rights Reserved. Copyright 2017

If you discover any item below are damaged or lost, please contact your vendor immediately.

- MP-4815 x1
- This Quick Reference Guide x1
- Manual DVD x1
- MP-4815 EPE Right x1
- MP-4815 EPE Left x1

**Specifications**

**2nd Display**

|                     |   |
|---------------------|---|
| Display             | 15-inch LCD panel   |
| Resolution          | LVDS 1024x768 dots XGA (24-bit)   |
| Brightness          | Typ. 300 cd/ m <sup>2</sup>   |
| Backlight Lamp      | Life time: min. 50,000 hours  |
| Touch Panel         | P-CAP touch (Bezel free) or Resistive Touch   |
| Touch Control Board | Only for 15-inch Resistive Touch Panel (USB Interface)  |
| Speaker             | 3W+3W@4 ohm speaker   |
| Power Supply        | DC12V/3.33A/ 40W Power Adapter, 90 ~240 Vac, 50/60Hz  |
| Wall Mount          | VESA Mount 100x100 mm   |
| Dimension (WxHxD)   | 367 x 300 x 38 mm   |
| Weight              | <ul style="list-style-type: none"> <li>• MP-4815: 3.1 kg</li> <li>• MP-4815 2nd Display + PA-6322: 11 kg</li> </ul> |
| Certificate         | CE  |

**Rear I/O Ports**

|       |                                       |
|-------|---------------------------------------|
| DC IN | 1 x DC-IN port                        |
| USB   | 1 x USB 2.0 port, Type B (downstream) |
| VGA   | 1 x VGA port                          |

**Optional Integrated Module**

|                 |  |
|-----------------|--|
| Module Mounting | Provides mounting holes on right side to fix other devices |
|-----------------|--|

**Optional Integrated Devices**

|        |                               |
|--------|-------------------------------|
| Camera | Camera module (USB Interface) |
|--------|-------------------------------|

**Environment**

|                 |                             |
|-----------------|-----------------------------|
| Operating Temp. | 0°C ~ 40°C (32°F ~ 104°F)   |
| Storage Temp.   | -20°C ~ 60°C (-4°F ~ 140°F) |
| Humidity        | 10% ~ 90%                   |

**System View**

**Front View**

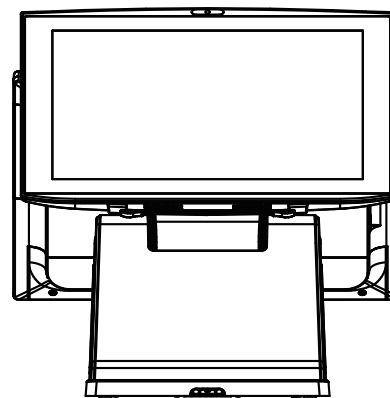

**Side View**

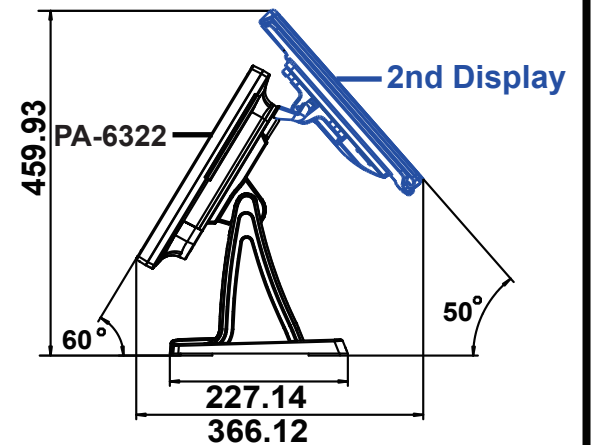

**REAR I/O**

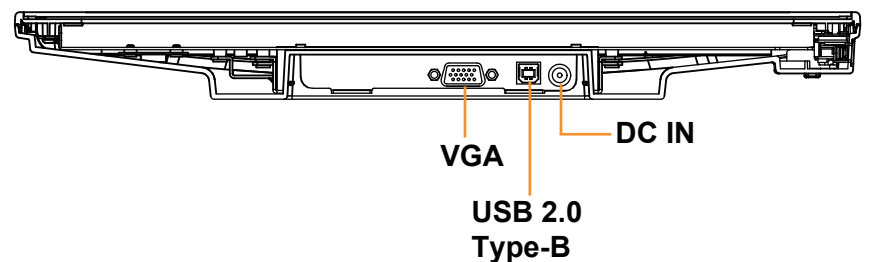

**Quarter View**

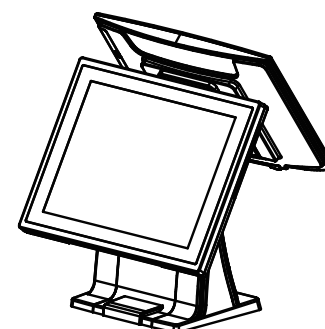

# MP-4815

## 15" 2nd Display

### Jumper Setting

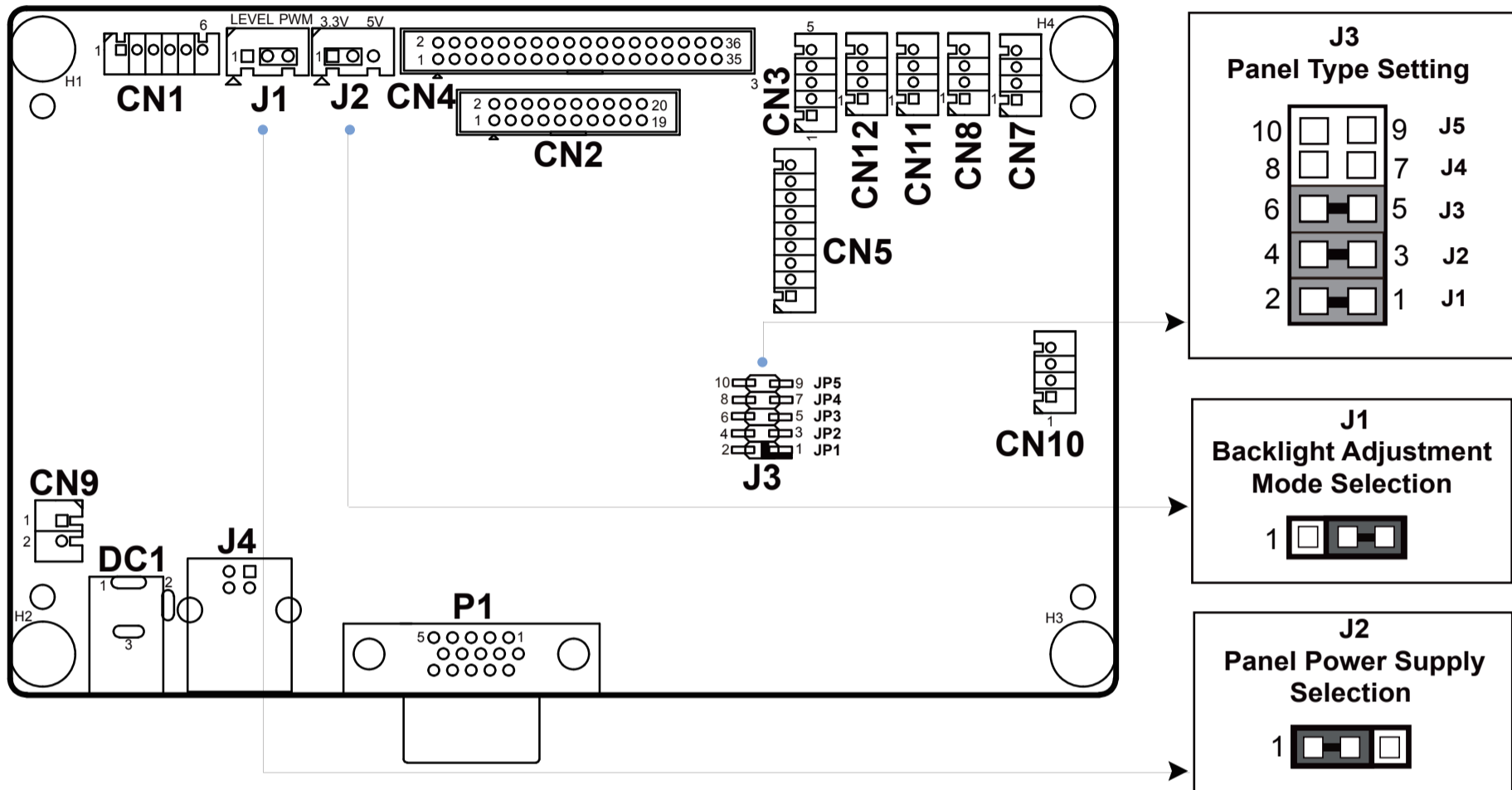

**CAUTION!** Danger of explosion may occur if the battery is replaced incorrectly. Replace batteries only with the same or equivalent type recommended by the manufacturer. Dispose the used batteries according to the manufacturer's instructions.

### Safety Precaution

The following messages are safety reminders on how to protect your system from damages, and thus extend the life cycle of the system.

1. Check the Line Voltage
  - The operating voltage for the power supply should cover the range of 9V~36V DC; otherwise, the system may be damaged.
2. Environmental Conditions
  - Place your MP-4815 on a sturdy, level surface. Be sure to allow enough room on each side to have easy access.
  - Avoid moving the system rapidly from a hot place to a cold place or vice versa because condensation may come from inside of the system.
  - Place MP-4815 against strong vibrations, which may cause hard disk failure.
3. Handling
  - Do not turn the system upside down. This may cause the hard drive to malfunction.

- Do not allow foreign objects to fall into this product.
  - If water or other liquid spills into this product, unplug the power cord immediately.
4. Good Care
    - When the outside of the case is stained, remove the stain with neutral washing agent with a dry cloth.
    - If dust has been accumulated on the outside, remove it by using a vacuum cleaner specially made for computers.

**CAUTION!**

Danger of explosion if battery is incorrectly replaced. Replace only with the same or equivalent type recommended by the manufacturer. Dispose of used batteries according to the manufacturer's instructions.

**WARNING!**

Some internal parts of the system may have high electrical voltage. Therefore we strongly recommend qualified engineers open and disassemble the system.

**Packing Checklist**

**MP-4815**

**Quick Reference Guide**

Designed for PA-6722



Ver. Q1

All Rights Reserved. Copyright 2017

If you discover any item below are damaged or lost, please contact your vendor immediately.

- MP-4815 x1
- This Quick Reference Guide x1
- Manual DVD x1
- MP-4815 EPE Right x1
- MP-4815 EPE Left x1

**Specifications**

**2nd Display**

|                     |   |
|---------------------|---|
| Display             | 15-inch LCD panel   |
| Resolution          | LVDS 1024x768 dots XGA (24-bit)   |
| Brightness          | Typ. 300 cd/ m <sup>2</sup>   |
| Backlight Lamp      | Life time: min. 50,000 hours  |
| Touch Panel         | P-CAP touch (Bezel free) or Resistive Touch   |
| Touch Control Board | Only for 15-inch Resistive Touch Panel (USB Interface)  |
| Speaker             | 3W+3W@4 ohm speaker   |
| Power Supply        | DC12V/3.33A/ 40W Power Adapter, 90 ~240 Vac, 50/60Hz  |
| Wall Mount          | VESA Mount 100x100 mm   |
| Dimension (WxHxD)   | 367 x 300 x 38 mm   |
| Weight              | <ul style="list-style-type: none"> <li>• MP-4815: 3.1 kg</li> <li>• MP-4815 2nd Display + PA-6722: 11 kg</li> </ul> |
| Certificate         | CE  |

**Rear I/O Ports**

|       |                                       |
|-------|---------------------------------------|
| DC IN | 1 x DC-IN port                        |
| USB   | 1 x USB 2.0 port, Type B (downstream) |
| VGA   | 1 x VGA port                          |

**Optional Integrated Module**

|                 |  |
|-----------------|--|
| Module Mounting | Provides mounting holes on right side to fix other devices |
|-----------------|--|

**Optional Integrated Devices**

|        |                               |
|--------|-------------------------------|
| Camera | Camera module (USB Interface) |
|--------|-------------------------------|

**Environment**

|                 |                             |
|-----------------|-----------------------------|
| Operating Temp. | 0°C ~ 40°C (32°F ~ 104°F)   |
| Storage Temp.   | -20°C ~ 60°C (-4°F ~ 140°F) |
| Humidity        | 10% ~ 90%                   |

**System View**

**Front View**

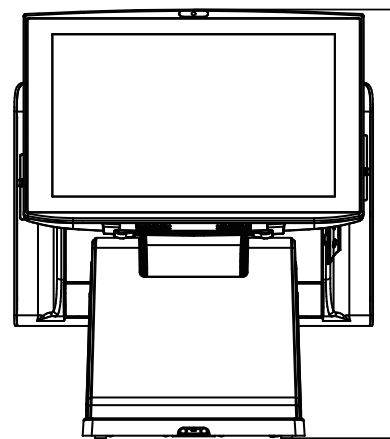

**Side View**

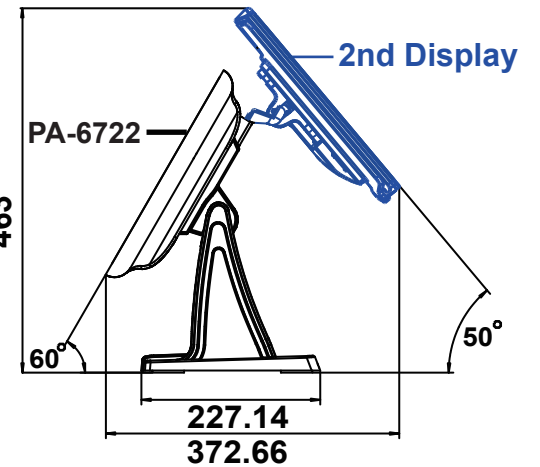

**REAR I/O**

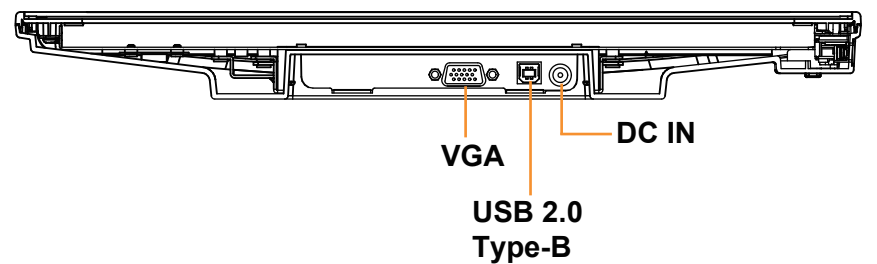

**Quarter View**

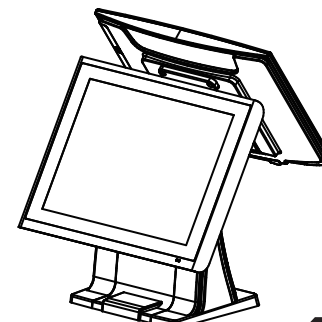

# MP-4815

## 15" 2nd Display

### Jumper Setting

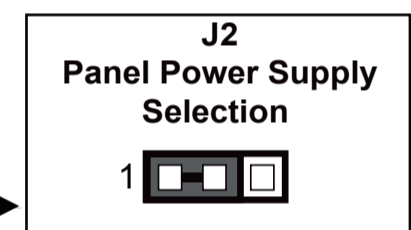
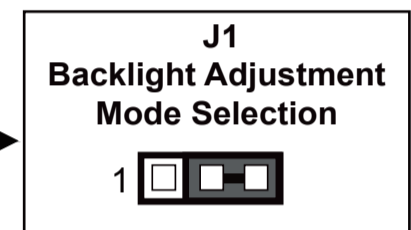
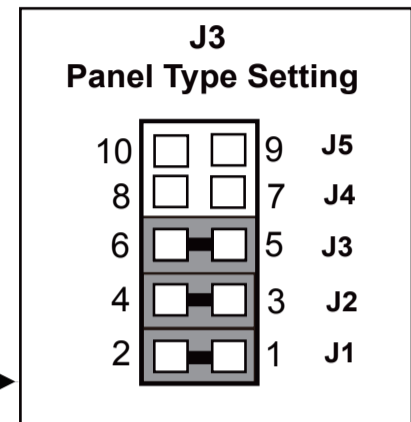
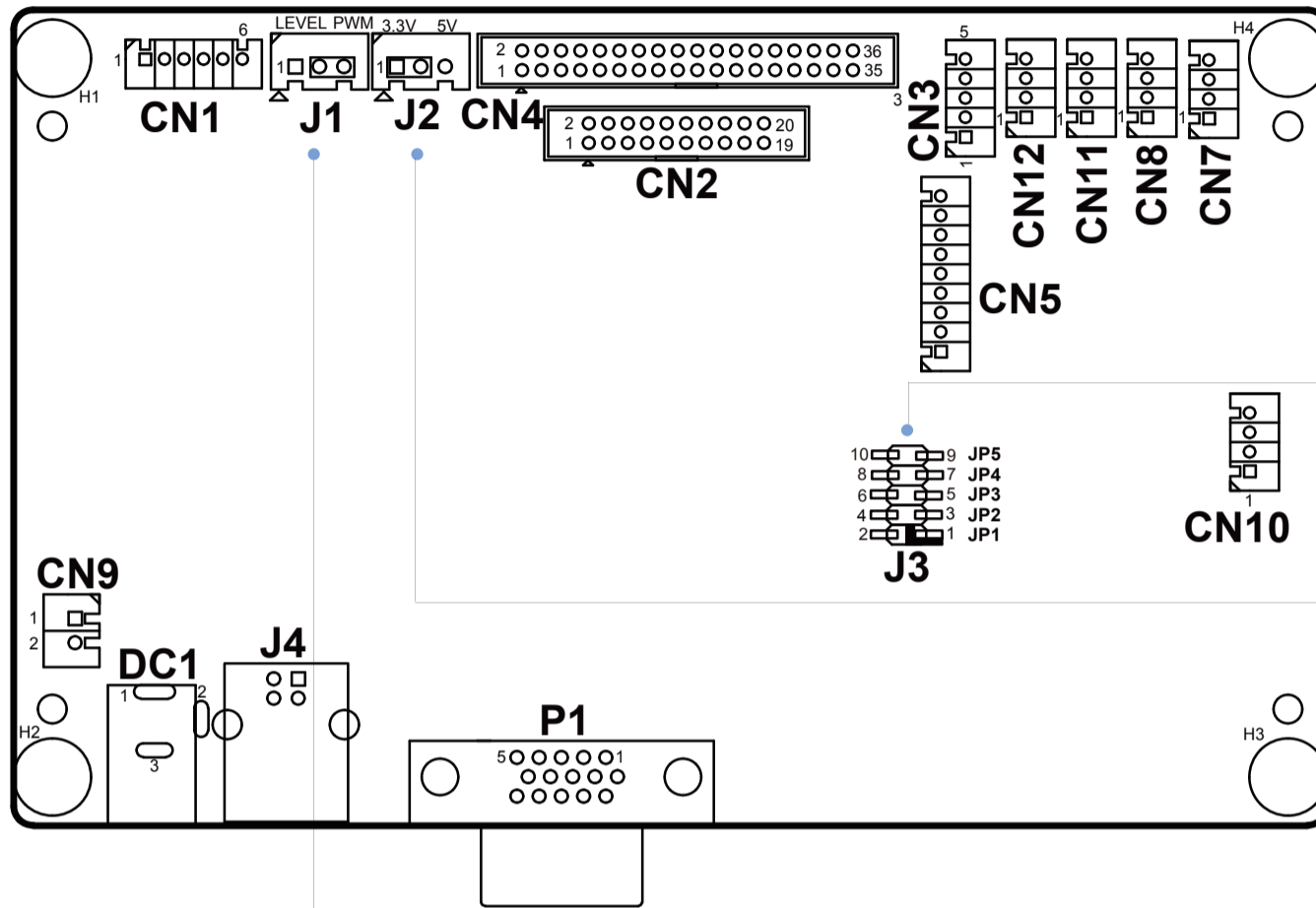

**CAUTION!** Danger of explosion may occur if the battery is replaced incorrectly. Replace batteries only with the same or equivalent type recommended by the manufacturer. Dispose the used batteries according to the manufacturer's instructions.

### Safety Precaution

The following messages are safety reminders on how to protect your system from damages, and thus extend the life cycle of the system.

1. Check the Line Voltage

- The operating voltage for the power supply should cover the range of 9V~36V DC; otherwise, the system may be damaged.

2. Environmental Conditions

- Place your MP-4815 on a sturdy, level surface. Be sure to allow enough room on each side to have easy access.
- Avoid moving the system rapidly from a hot place to a cold place or vice versa because condensation may come from inside of the system.
- Place MP-4815 against strong vibrations, which may cause hard disk failure.

3. Handling

- Do not turn the system upside down. This may cause the hard drive to malfunction.

- Do not allow foreign objects to fall into this product.
  - If water or other liquid spills into this product, unplug the power cord immediately.
4. Good Care
- When the outside of the case is stained, remove the stain with neutral washing agent with a dry cloth.
  - If dust has been accumulated on the outside, remove it by using a vacuum cleaner specially made for computers.

**CAUTION!**

Danger of explosion if battery is incorrectly replaced. Replace only with the same or equivalent type recommended by the manufacturer. Dispose of used batteries according to the manufacturer's instructions.

**WARNING!**

Some internal parts of the system may have high electrical voltage. Therefore we strongly recommend qualified engineers open and disassemble the system.

**Packing Checklist**

**MP-4815**

**Quick Reference Guide**

Designed for PA-6980

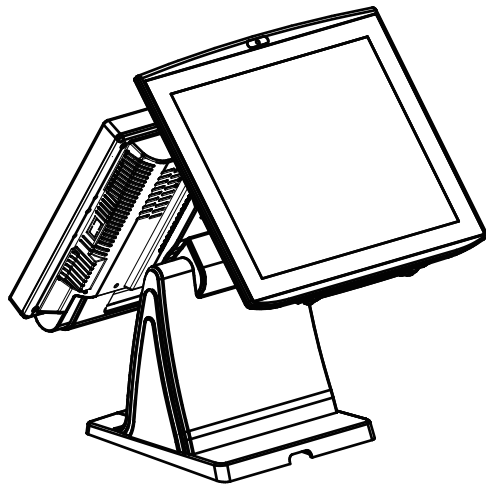

Ver. Q1

All Rights Reserved. Copyright 2017

If you discover any item below are damaged or lost, please contact your vendor immediately.

- MP-4815 x1
- This Quick Reference Guide x1
- Manual DVD x1
- MP-4815 EPE Right x1
- MP-4815 EPE Left x1

**Specifications**

**2nd Display**

|                     |   |
|---------------------|---|
| Display             | 15-inch LCD panel   |
| Resolution          | LVDS 1024x768 dots XGA (24-bit)   |
| Brightness          | Typ. 300 cd/ m <sup>2</sup>   |
| Backlight Lamp      | Life time: min. 50,000 hours  |
| Touch Panel         | P-CAP touch (Bezel free) or Resistive Touch   |
| Touch Control Board | Only for 15-inch Resistive Touch Panel (USB Interface)  |
| Speaker             | 3W+3W@4 ohm speaker   |
| Power Supply        | DC12V/3.33A/ 40W Power Adapter, 90 ~240 Vac, 50/60Hz  |
| Wall Mount          | VESA Mount 100x100 mm   |
| Dimension (WxHxD)   | 367 x 300 x 38 mm   |
| Weight              | <ul style="list-style-type: none"> <li>• MP-4815: 3.1 kg</li> <li>• MP-4815 2nd Display + PA-6980: 13 kg</li> </ul> |
| Certificate         | CE  |

**Rear I/O Ports**

|       |                                       |
|-------|---------------------------------------|
| DC IN | 1 x DC-IN port                        |
| USB   | 1 x USB 2.0 port, Type B (downstream) |
| VGA   | 1 x VGA port                          |

**Optional Integrated Module**

|                 |  |
|-----------------|--|
| Module Mounting | Provides mounting holes on right side to fix other devices |
|-----------------|--|

**Optional Integrated Devices**

|        |                               |
|--------|-------------------------------|
| Camera | Camera module (USB Interface) |
|--------|-------------------------------|

**Environment**

|                 |                             |
|-----------------|-----------------------------|
| Operating Temp. | 0°C ~ 40°C (32°F ~ 104°F)   |
| Storage Temp.   | -20°C ~ 60°C (-4°F ~ 140°F) |
| Humidity        | 10% ~ 90%                   |

**System View**

**Front View**

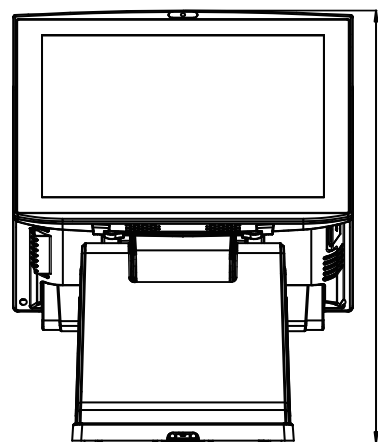

**Side View**

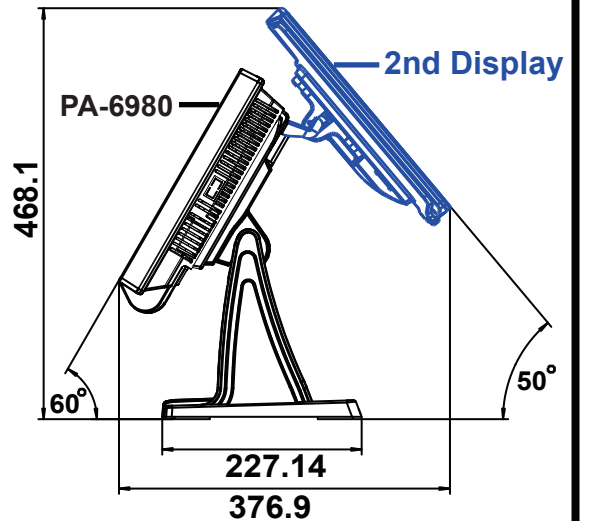

Unit: mm

**REAR I/O**

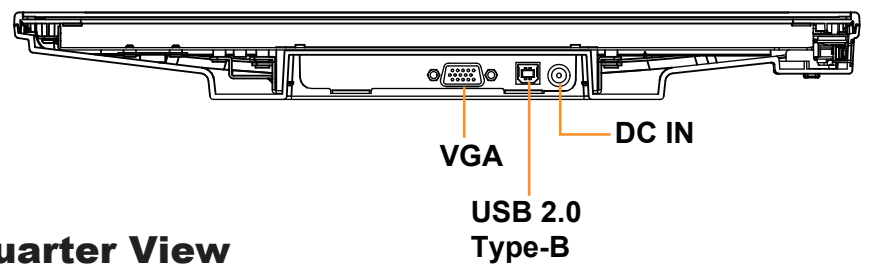

**Quarter View**

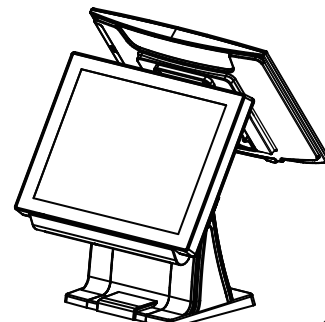

# MP-4815

## 15" 2nd Display

### Jumper Setting

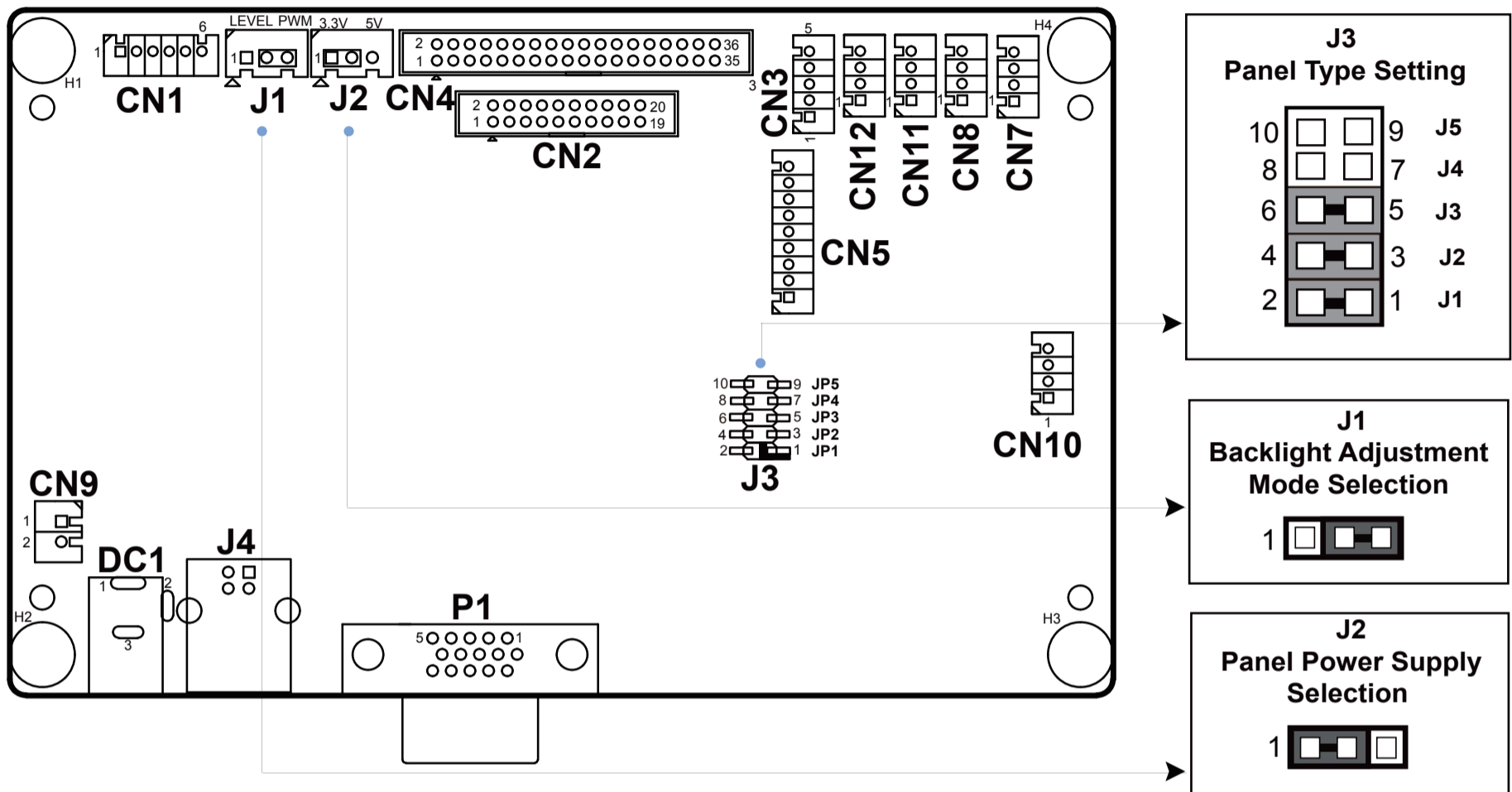

**CAUTION!** Danger of explosion may occur if the battery is replaced incorrectly. Replace batteries only with the same or equivalent type recommended by the manufacturer. Dispose the used batteries according to the manufacturer's instructions.

### Safety Precaution

The following messages are safety reminders on how to protect your system from damages, and thus extend the life cycle of the system.

1. Check the Line Voltage
  - The operating voltage for the power supply should cover the range of 9V~36V DC; otherwise, the system may be damaged.
2. Environmental Conditions
  - Place your MP-4815 on a sturdy, level surface. Be sure to allow enough room on each side to have easy access.
  - Avoid moving the system rapidly from a hot place to a cold place or vice versa because condensation may come from inside of the system.
  - Place MP-4815 against strong vibrations, which may cause hard disk failure.
3. Handling
  - Do not turn the system upside down. This may cause the hard drive to malfunction.

- Do not allow foreign objects to fall into this product.
  - If water or other liquid spills into this product, unplug the power cord immediately.
4. Good Care
    - When the outside of the case is stained, remove the stain with neutral washing agent with a dry cloth.
    - If dust has been accumulated on the outside, remove it by using a vacuum cleaner specially made for computers.

**CAUTION!**

Danger of explosion if battery is incorrectly replaced. Replace only with the same or equivalent type recommended by the manufacturer. Dispose of used batteries according to the manufacturer's instructions.

**WARNING!**

Some internal parts of the system may have high electrical voltage. Therefore we strongly recommend qualified engineers open and disassemble the system.