

MH-0616



6" Android 10 Rugged Handy Terminal with Qualcomm® S660 Octa-core CPU (up to 2.2 GHz)



Features

- 6" HD Display (720 x 1280 resolution/ 500 nits/ 30,000 hours) OCA direct bonding with Anti-Fingerprint/ Corning Gorilla Glass P-Cap Multi-Touch for sunlight readable & various touch operating (Finger/ Stylus/ Glove/ Raindrop)
- Qualcomm® S660 octa-cores 2.2GHz with 4+64GB eMCP/ Android 10
- IP65 Rating & 1.2M Drop Test (MIL-STD-810H)
- Removable Battery & up to 10 hours operating (JEITA test v2.0)
- Multi-Peripherals & Accessories (WiFi 5+BT5.0/ 4G LTE+GNSS/ 2D Barcode scanner/ 13MP Rear Camera/ 3-in-1 Payment Card Reader/ Charging Stand/ Protective Case/ Hand Strap/ Shoulder Strap/ Stylus, etc)
- Reduce Maintenance & Equipment Cost with ProxEye Mobile Device Management
- Light Weight 330g (Tablet only)
- USB Power Delivery & Quick Charge™ 3.0
- Embedded Time of Flight (ToF) Sensor for dimension measurement

Highlights



Dimensions

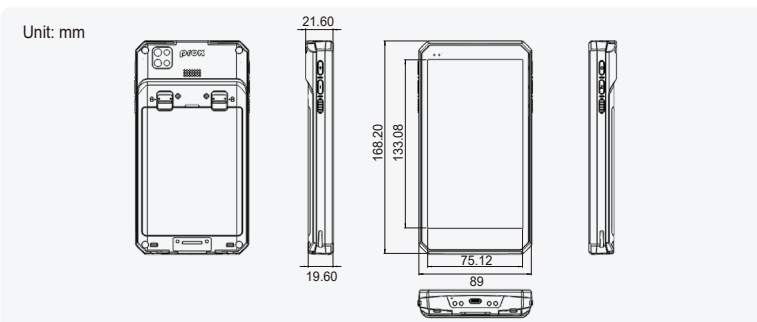

Application

- Automation
- Retail
- Asset Tracking
- Food Service
- Hospitality
- Warehouse
- Logistics
- Manufacturing
- Power Patrol Inspection



Specifications

Display Specification	
Size	6"
Resolution	720 x 1280 pixels (High Definition)
Brightness	500 nits for Sunlight readable
Backlight Lifetime	30,000 hours
Touch	P-CAP Multi-Touch with Anti-Fingerprint & Corning Gorilla Glass (Support Finger/ Stylus/ Glove/ Raindrop)
Bonding Technology	LCD Optical Clear Adhesive direct bonding with Touch
System Specification	
CPU	Qualcomm® S660 Octa-Cores 2.2GHz
Operating System	Android 10
Memory	4+ 64GB eMCP
Storage	1 x 0.8W Speaker & 2 x Digital Mic
Audio	G-Sensor, Ambient Light Sensor
Sensor	1 x tri-color LED (Green/ Yellow/ Red) for Power/ Battery status indication
LED Indicators	1 x Power button, 1 x Function key, 2 x Scan buttons, 1 x Volume+, 1 x Volume-
Buttons	1S1P 3.85V/ 4380mAh/ 16.8Wh, Removable Battery, up to 10 hours operating (per JEITA test v2.0)
Battery	Quick Charge™ 3.0 30W for tablet & Charging Stand
AC Adapter	1 x USB Type-C cable for Charging with AC Adapter & Data Transmission
USB Cable	89 x 168 x (18.6-19.6) mm (Tablet only)
Dimension (W x H x D)	330 g (Tablet only)
Weight	
I/O Ports	
USB	1 x USB 3.0 Type-C for Charging with Quick Charge™ 3.0 & Data Transmission, 1 x USB 2.0 with 5 pins internal connector for Expansion Device with customized back cover (such as 3-in-1 Card Reader)
MicroSD Slot	1 x internal slot for MicroSD up to 128GB
Nano-SIM Slot	1 x internal slot for 4G LTE
Pogo Pin	4 x Pin (For Cradle Charger)
Communications	
WLAN	Wi-Fi 802.11 a/b/g/n/ac (WiFi 5)
Bluetooth	Bluetooth 5.0
GNSS	GPS, GLONASS (Optional)
WWAN	4G LTE for North America/ Europe/ Taiwan/ Japan (Optional)
Optional Peripherals & Accessories	
1D/2D Barcode	Honeywell N6703
Camera	13MP Rear Camera with Auto-Focus, Flashlight
3D Camera	Embedded Time of Flight (ToF) Sensor for dimension measurement
RFID	Support ISO14443A/ MifaireS50(R/W)/ ISO14443B Des Fires (Read UID Only) ISO15693 I-Code SL1 (R/W)/ ISO18092 SONY Felica/ Mifare Classic1K/ 4K type1/ Mifare Ultralight (Type 2) & Mifare DesFire EV1/EV2/EV3 (Type4)
Charging Stand	For tablet & Battery charging
Protective Case	Support 1.8m Drop test
Hand Strap	Hand strap attaches to tablet sliding handle Easily detachable with clips underneath Snaps securely in place
Shoulder Strap	Must be used with Protective Case
Stylus	Capacitive Stylus
TP Protector	9H glass Touch Panel Protector
Reliability & Environment	
ESD	Contact +/-8kV & Air +/- 15kV
EMI	Class B
IP Rating	IP65 per IEC 60529
Drop Test	1.2m per MIL-STD-810H
Tumble Test	1000 tumbles, 0.5m per IEC 60068-2-32
Shock	Per MIL-STD-810H
Vibration	Per MIL-STD-810H
Operating Temp.	-10°C~50°C (Discharging) & 0°C~40°C (Charging)
Storage Temp.	-20°C~60°C
Humidity	10%~90% non-condensing
Certification	
Certificate	CE, FCC, BSMI, PSE, Battery with UN 38.3 & IEC 62133

* All information contained in this document is subject to change without prior notice. Please log on www.protech.com.tw to acquire latest information. For detail mechanics drawing, please contact our sales.